

SMARTYCAM

User Manual



Dear Customer,

SmartyCam, the new on board camera with data overlay, descends from the great AIM experience in developing data acquisition systems, mainly for motorsports applications.

SmartyCam can review racing performances on a PC or TV, merging crystal clear images with graphical data coming from integrated GPS and three-axial accelerometer, as well as from the ECU (Engine Control Unit from here onward ECU) or from an AIM logger: that is why **SmartyCam** can be used in any situation, on any sort of vehicle.

Acquired data can be overlaid to frames in a great variety of formats, configurable by the user. On a Micro SD card hours of movies and sounds can be saved: ratio depends on the video quality and is approximately 1 hour = 2 Giga.

It is recommended to periodically check www.SmartyCam.com for software and/or firmware updates or – recommended option – subscribe the www.SmartyCam.com newsletter to receive all updates in real time.

Warning: this user manual is regularly updated. All new versions can be found on www.SmartyCam.com. Please make sure your manual is the latest version available: the issue number of each manual is reported on the top of the page.

INDEX

SmartyCam Quick Guide	5
1 – SmartyCam stand alone.....	5
2 – SmartyCam Slave (connected to AIM logger/the ECU via ECU Bridge)	6
Chapter 1 – SmartyCam: kit and optional items	7
1.1 – SmartyCam kits.....	7
1.2 – ECU bridge kits	7
1.3 – SmartyCam optional items: cables and external microphone.....	8
Chapter 2 – Data sampled by SmartyCam stand alone/slave	9
Chapter 3 – SmartyCam connections	10
3.1 – Connecting SmartyCam stand alone.....	10
3.2 – Connecting SmartyCam in Slave expansion mode with ECU Bridge	11
3.3 – SmartyCam in Slave expansion mode with AIM loggers.....	12
Chapter 4 – How to charge SmartyCam battery	13
4.1 – Battery charging via USB	13
4.2 – Battery charging via connector.....	13
Chapter 5 – SmartyCam configuration	14
Chapter 6 – How to use SmartyCam	15
6.1 – “Battery and Memory Status” field.....	15
6.2 – How to switch SmartyCam on/off	16
6.3 – “Online” status (or mode)	16
6.3.1 – “ <i>SETTINGS</i> ” option.....	17
6.3.1.1 – Accelerometer calibration: “ <i>ACCEL CALIBR</i> ” option.....	17
6.4 – How to record videos.....	18
6.4.1 – Manual recording	18
6.4.2 – Automatic recording.....	19
6.5 – SmartyCam recording support.....	19
Chapter 7– Downloading data and viewing SmartyCam videos	20
7.1 – Downloading data.....	20
7.2 – Viewing SmartyCam videos	20
7.2.1 – Viewing SmartyCam videos on the PC.....	20
7.2.2 – Viewing SmartyCam videos on the TV.....	20
Chapter 8 – SmartyCam Maintenance	20
Appendix “A” – Technical specifications	21
Appendix “B” – SmartyCam Pinout	22

INTRODUCTION

SmartyCam features three different working modes.

Stand alone: for non-motorsport applications or for motorsport applications whenever there is no ECU nor AIM data acquisition system/data logger (from here onward: logger).

Slave connected to the vehicle ECU: for motorsport applications to sample data from the ECU without the need to sample data from additional sensors. In this case an AIM ECU Bridge is required. It is described in www.SmartyCam.com, “Accessories” area.

Slave connected to an AIM logger: for motorsport applications when a detailed analysis of performances is needed, desired. In this case the ECU bridge is not required because connection to the vehicle ECU is made using an AIM logger. **SmartyCam** is supported by the following loggers:

- MXL,
- EVO3,
- EVO4,
- MyChron4.

Information concerning these loggers are on “Car” and “Kart” – **MyChron4** only – section of www.aim-sportline.com.

SmartyCam Quick Guide

SmartyCam is a very flexible product: it has been designed to fit the needs of an entry level user as well as those of a more professional motorsport driver. This flexibility implies the need for the user to configure the logger using the proper software.

This quick guide includes all essential information for an easy and immediate **SmartyCam** use. Any other information is to be looked for in the indicated chapter/paragraph.

1 – SmartyCam stand alone

Battery charge

It is recommended to charge the battery via socket (Chapter 4) and not via PC.

Insert the micro SD

The housing is under the rear flip of the product (close carefully after insertion).

Power on SmartyCam (and enable “AUTO REC” function if desired)

Power on is made through the central button (Paragraph 6.2)

SmartyCam comes with “AUTO REC” function **disabled**: recording is started/stopped manually pressing “Rec” and – at the end of the recording session – “Stop” (Paragraph 6.4.1). Enabling “AUTO REC” recording is automatically started/stopped when speed overcomes 10 km/h or acceleration overcomes a fixed threshold value (Paragraph 6.4.2). This way there is no need of intervention on the camera while travelling.

Install SmartyCam in the desired position

Install **SmartyCam** in the right position to shoot: the display shows a frame preview.

Optional kits are available for any kind of installation (roll-bar, with suction cup, etc.). They are shown on www.SmartyCam.com, Accessories>>Bracket kits.

Calibrating the accelerometer

Accelerometer calibration is important because it influences the accuracy of acceleration measurement as well as the taken images centring (Paragraph 6.3.1.1).

Recording movies

Shooting can be managed both manually and automatically (Paragraph 6.4). **SmartyCam** movies are in **.avi format with H.264 codec**. It is suggested to use **VLC player** (downloadable from <http://www.videolan.org/vlc/>). To edit movies use AVS Video Editor (downloadable from <http://www.avsmmedia.com/it/avs-video-editor.aspx>).

Downloading movies on a PC

SmartyCam allows to download data both via USB and manually extracting the micro SD from the rear flip of **SmartyCam** and inserting it in the PC reader (Chapter 7). It is reminded to **use only a 2.0 type USB port**.

Install SmartyManager software on the PC

It is needed to: download new firmware versions from www.SmartyCam.com – download area – and update **SmartyCam** functionalities, modify/add/delete overlay configurations and download/see movies (Chapter 5). **SmartyManager** is on the CD of **SmartyCam** kit and can be downloaded from the same website. **Periodically check possible new software/firmware releases**.

2 – SmartyCam Slave (connected to AIM logger/the ECU via ECU Bridge)

Install SmartyManager and Race Studio 2 software on the PC. The first one is needed to download new firmware versions from download area of www.SmartyCam.com and update **SmartyCam** functionalities, modify/add/delete overlay configurations – if desired – and download/see **SmartyCam** movies (Chapter 5). The CD included in **SmartyCam** kit contains **SmartyManager** and **Race Studio 2** that can also be downloaded from www.aim-sportline.com, download area >>software section. **Periodically check possible new software/firmware releases.**

Configure the logger (or ECU Bridge) with Race Studio 2

See **Race Studio Configuration** user manual, downloadable from download area>>software section of www.aim-sportline.com to know how to configure each logger and ECU Bridge.

Configure SmartyCam with SmartyManager

See SmartyManager user manual downloadable from www.aim-sportline.com download area>>software section.

Connect SmartyCam al logger

Each logger connection modes are showed in “Connection” area of www.SmartyCam.com.

Insert the micro SD

The housing is under the rear flip of the product (carefully close after insertion).

Install SmartyCam in the desired position

Install **SmartyCam** in the right position to shoot: the display shows a frame preview. Optional kits are available for any kind of installation (roll-bar, with suction cup, etc.). They are shown on www.SmartyCam.com, Accessories>>Bracket kits.

Power on SmartyCam (and enable “AUTO REC” function if desired)

Power on is made through the central button (Paragraph 6.2)

SmartyCam comes with “AUTO REC” function **disabled**: recording is started/stopped manually pressing “Rec” and – at the end of the recording session – “Stop” (Paragraph 6.4.1). Enabling “AUTO REC” recording is automatically started/stopped when speed overcomes 10 km/h or acceleration overcomes a fixed threshold value (Paragraph 6.4.2). This way there is no need of intervention on the camera while travelling.

Calibrating the accelerometer

Accelerometer calibration is important because it influences the accuracy of acceleration measurement as well as the taken images centring (Paragraph 6.3.1.1).

Recording movies

Shooting can be managed both manually and automatically (Paragraph 6.4). **SmartyCam** movies are in **avi format with H.264 codec**. It is suggested to use **VLC player** (downloadable from <http://www.videolan.org/vlc/>). To edit movies use **AVS Video Editor** (downloadable from <http://www.avsmmedia.com/it/avs-video-editor.aspx>).

Downloading movies on a PC

SmartyCam allows to download data both via USB and manually extracting the micro SD from the rear flip of **SmartyCam** and inserting it in the PC reader (Chapter 7). It is reminded to **use only a 2.0 type USB port**.

Chapter 1 – SmartyCam: kit and optional items

SmartyCam package includes a complete kit that permits standard usage: in this manual some optional items are also shown, which can be useful in particular situations.

1.1 – SmartyCam kits

Stand alone kit: X90SMYC00

- 1 – **SmartyCam**;
- 1 – power supply
- 1 – adapter
- 1 – power and battery charge cable;
- 1 – USB cable for data download and battery charge;
- 1 – 4 Giga Micro SD;
- 1 – user manual;
- 1 – CD containing **SmartyManager** software and USB driver.

Slave kit with ECU Bridge or AIM logger (EVO3 Pro/Pista, EVO4, MXL Strada/Pista /Pro05, MyChron4):

- X90SMYCEC2 with 2m CAN cable
- X90SMYCEC4 with 4m CAN cable

- 1 – **SmartyCam**;
- 1 – power supply;
- 1 – adapter
- 1 – 2m or 4m CAN cable (for AIM logger/ECU Bridge connection);
- 1 – USB cable for data download and battery charge;
- 1 – 4 Giga Micro SD;
- 1 – user manual
- 1 – CD containing **SmartyManager + Race Studio 2** software and USB drivers.

Warning: to use SmartyCam in slave mode an ECU Bridge (optional) or the appropriate AIM logger is needed.

1.2 – ECU bridge kits

There are two available ECU Bridges, required to connect **SmartyCam** to the vehicle ECU. Their part number changes according to the communication protocol they are equipped with.

- ECU Bridge with CAN/RS232 communication protocol: X90BGGPI2R
- ECU Bridge with CAN/K Line communication protocol: X90BGGPI2K

Each ECU Bridge kit includes:

- 1 – ECU Bridge
- 1 – USB cable.

Refer to www.SmartyCam.com, accessories area for further information concerning ECU Bridges.

1.3 – SmartyCam optional items: cables and external microphone

SmartyCam optional tools can be connected to it using the 7 pins connector placed on the camera rear and shown here below.



SmartyCam comes with dedicated cables that guarantee its proper working.

- The standalone kit comes with battery charge and power cable code V02566150.
- The slave kit comes with 2m, 4m battery charge and CAN connection cable.

An additional **external microphone** can be useful, for example, to a driver that wish to communicate with its technical.

- Power cable with CAN and microphone (code V02566100 for 2m cable, V02566240 with 4m cable): this cable allows **SmartyCam** to connect to an external 12V power source to enable an external microphone, automatically mixed with the internal microphone and to connect via CAN to an AIM logger or an ECU Bridge. Refer to www.SmartyCam.com, “Connections” area for further information.
- External microphone (code X90MESMC00): additional microphone automatically mixed with the internal one by the on board camera. It plugs directly in the 7 pins connector placed on the camera rear. Refer to www.SmartyCam.com, “Accessories” area for further information.

Chapter 2 – Data sampled by SmartyCam stand alone/slave

As mentioned above, according to its working mode, **SmartyCam** provides different information.

In **Stand Alone** mode, **SmartyCam** gets data from the integrated GPS and three-axial accelerometer:

- position;
- GPS speed;
- acceleration
- lap time;
- distance;
- track mapping.

When connected to an AIM logger (**EVO3 Pro/Pista**, **EVO4**, **MXL Strada/Pista/Pro05** or **MyChron4**) or an ECU (via **ECU bridge**), **SmartyCam** can visualize in graphical overlay:

- all info acquired in Stand Alone mode;
- all info coming from the vehicle ECU;
- all info sampled by the AIM logger (RPM, more speeds, LCU-ONE Lambda value, engaged gear, temperatures, pressures, etc...).

PLEASE NOTE: for further useful information check:

- www.aim-sportline.com website download area to know which ECU's are supported by AIM loggers and their connection/communication protocols;
- Race Studio Configuration user manual to understand how to configure AIM loggers, ECU Bridge included;
- each AIM logger user manual.

Chapter 3 – SmartyCam connections

The alternative **SmartyCam** modes (Stand Alone or Slave Expansion) require different connection procedures.

3.1 – Connecting SmartyCam stand alone



SmartyCam stand alone can be connected in different ways:

- connection to the external power only: use the 7-pins connector highlighted in the image above and connect the power cables to a 12 Volts power source i.e. the vehicle battery. See appendix “B”tion to the external microphone only: the external microphone plugs directly in the 7 pins connector highlighted in the image here above.
- connection to optional cables and external microphone: use the 7-pins connector highlighted in the image here above and connect the power cables to an external 12 Volts power source.

3.2 – Connecting SmartyCam in Slave expansion mode with ECU Bridge

In order to receive the info provided by the vehicle ECU without any additional logger, **SmartyCam** must be used in Slave expansion mode and connected via CAN to an ECU Bridge, using the 7-pins connector placed on the product rear.

There are two available ECU Bridges version:

- code X90BGGPI2R for connection with aftermarket racing ECU with CAN or RS232 communication protocol.
- code X90BGGPI2K for connection with stock ECU through the OBDII, no matter if having a CAN communication protocol or the K line

Complete documentation on supported ECU is available at www.aim-sportline.com “Download” area, ECU connection section. Refer to appendix “B” of this user manual to know **SmartyCam** pinout, while **SmartyCam ECU Bridge** connection is shown at www.SmartyCam.com, “Connection” area, ECU Bridge section.

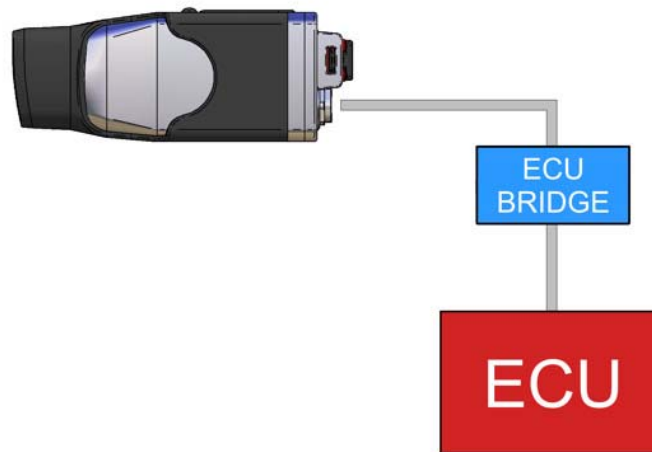

PLEASE NOTE: refer to Race Studio Configuration user manual for more info about ECU Bridge configuration, and to www.aim-sportline.com documentation download area for more info about ECU supported by AIM systems and their communication/connection protocols.

3.3 – SmartyCam in Slave expansion mode with AIM loggers

SmartyCam can visualize data sampled by an AIM logger (EVO3 Pro/Pista, EVO4, MXL Strada/Pista/Pro05 or MyChron4) and by the vehicle ECU. In this case it is necessary to connect SmartyCam via CAN to the logger, using the CAN cable inserted into the 7-pins connector placed on the product rear.

Please refer to appendix “B” of this manual for the SmartyCam pinout and to the user manuals of each AIM logger to know its pinout.

The image below shows SmartyCam connected to an EVO4 logger while SmartyCam-EVO4 connection is explained at www.SmartyCam.com, “Connection” area, EVO4 section..

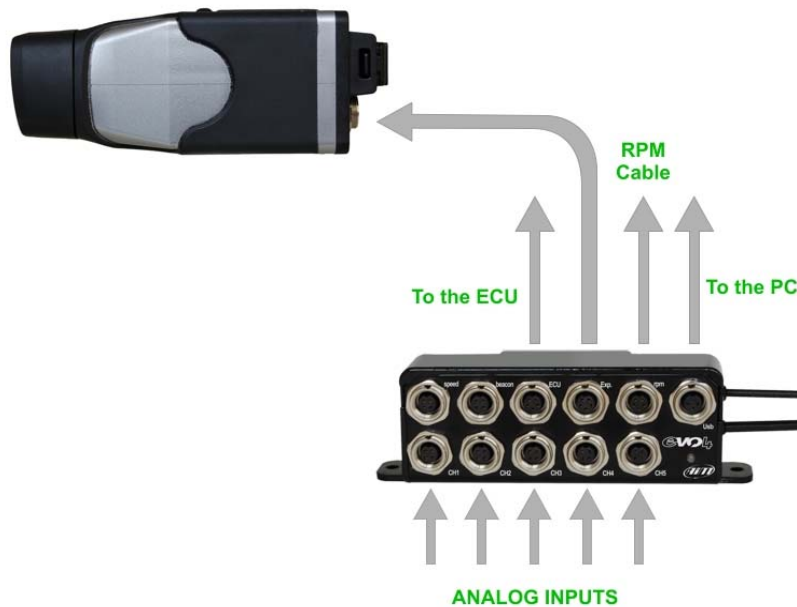

Chapter 4 – How to charge SmartyCam battery

SmartyCam is supplied with a 2000mAh 3.7 Volt rechargeable lithium battery. It can be charged using both the 7-pins connector and the USB port highlighted in the image below on the right. Connect **SmartyCam** to an external power source.

The battery charge status is shown in any **SmartyCam** page. Below on the left the related field is shown.



4.1 – Battery charging via USB

SmartyCam battery charging via USB has two possible options.

Socket charge (recommended):

- connect **SmartyCam** to the power supply using the cable included in the kit: it has to be plugged in the USB port placed in the product rear;
- insert the power supply plug in the socket.

In case of **PC charge** via USB (not recommended): connect **SmartyCam** directly to the PC on, using the cable included in the kit. **It is recommended not to use an USB hub.** It is also recommended to **use exclusively a 2.0 USB port.**

Please do not connect SmartyCam to the PC unless having previously installed SmartyManager software.

Warning: not all Personal computers USB ports provide enough power to charge SmartyCam and, due to the power supply limitation of the PC, battery charging is longer. Socket charge is then recommended.

4.2 – Battery charging via connector

SmartyCam battery can be charged also using the external power cable or the CAN cable (included in the specific kits) connected to the rear connector of the camera.

Chapter 5 – SmartyCam configuration

In order to configure **SmartyCam** data overlay¹ **SmartyManager** software – exclusively developed by AIM – needs to be used.

With **SmartyManager** it is possible to:

- change/add/cancel overlay configurations;
- download from www.smartycam.com “Download” area a new firmware release and upgrade with it **SmartyCam**;
- download **SmartyCam** movies;
- see SmartyCam movies.

This software is provided with a CD included in **SmartyCam** kits and can be downloaded from www.SmartyCam.com, “Download” area.

There are two possible **SmartyCam** configuration mode.

Connecting SmartyCam to the PC:

- set the preferred data overlay;
- transmit the new configuration to **SmartyCam**;
- **SmartyCam** will automatically set that configuration.

Not connecting SmartyCam to the PC:

- set the preferred data overlay;
- copy the new configuration on the MicroSD previously inserted in the PC reader;
- insert the Micro SD in **SmartyCam**;
- enter “Conf. load” option and select “Smarty Conf”;

PLEASE NOTE: before connecting SmartyCam to the PC it is mandatory installing SmartyManager software (see SmartyManager user manual at www.SmartyCam.com, download area)

- set the preferred data overlay;
- transmit the new configuration both to **SmartyCam** and to the **Micro SD**²;
- switch off/on **SmartyCam**;
- **SmartyCam** will automatically set that configuration.

Refer to SmartyManager user manual for data overlay configuration information

SmartyCam slave needs its master (AIM logger or ECU Bridge) configuration through **Race Studio 2** software, included in both the slave kits with 2m and 4m power cable).

PLEASE NOTE: SmartyCam configuration is independent from its master configuration: it is thereby unnecessary to modify it changing SmartyCam master.

¹ Selection of data to visualize, layout and position.

² Using the microSD in other SmartyCams, these will be loaded with the same configuration as the first one, without need of a PC connection. See LOAD CONF option (paragraph 6.3.1.).

Chapter 6 – How to use SmartyCam

SmartyCam is managed using the three buttons placed above the display: 1,2 and 3 in the image below.

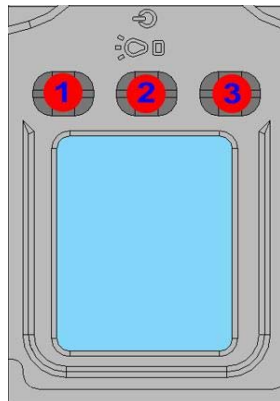

The menu on the display shows the functions related to each button, close to the button itself.

All **SmartyCam** pages are made up of three parts:

- **top** of page menu functions are shown;
- in the **middle** of the page specific info is displayed;
- in the **lower part** the “Battery and Memory Status” field is shown.

6.1 – “Battery and Memory Status” field

“**Battery and memory Status**” field constantly shows the level of battery charge and the remaining memory available for recording. “Online”, “GPS status” and “Lap Management” show the GPS signal strength.

The above indicator refers to the available memory, showing in black the used part and in grey the available memory. When available memory is lower than 300 kb the black part becomes red. The number right of the bar is the available space in Giga (in the image below **SmartyCam** is working with a 4 Giga Micro SD). Please note that Micro SD icon becomes red when **SmartyCam** is recording, or when it is in “Player” mode.

WARNING: MicroSD will be permanently damaged if it is removed from SmartyCam when its icon in the left bottom of the screen is red.

The below indicator shows the battery charge status while the number on the right shows the percentage of available battery (image here below)

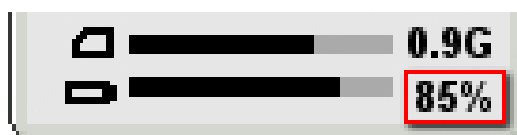

6.2 – How to switch SmartyCam on/off

SmartyCam can be switched on in two ways:

- pressing “2” button, or
- connecting the external power cable to **SmartyCam**: as soon as the camera detects the 12V power on pin 3 the of 7 pins connector (see appendix “B”) it switches on.

SmartyCam can be switched off in the following ways:

- pressing “2” button any time “Off” option is available
- pressing “2” button for 10 seconds. This forced option is to be used ONLY in case the camera locks up, as this method can lead to cancellation of some of the latest recorded data/images
- automatic switch-off: if still for a fixed time (no button pushed, no acceleration/speed detected), **SmartyCam** will switch automatically off. In standalone mode auto power off is after 15 minutes of inactivity while in slave mode it is after 6 hours.

NOTE: this function can be disabled in “**SETTINGS**” menu (“**AUTO POWEROFF**” option).

6.3 – “Online” status (or mode)

When **SmartyCam** is switched on, three options appear:

- Rec starts recording process (see paragraph 6.4)
- Off switches off the camera (see paragraph 6.2)
- Menu enters **SmartyCam** menu

Clicking “**Menu**” a new page appears, showing (in loop) the following options:

PLAYER	manages recorded videos: “ Down ” scrolls the list of videos and “ Sel ” selects the desired video. Once a video selected, it is possible to view it (“ Play ”) or cancel it (“ Del ”).
GPS STATUS	shows the connected satellites and the signal strength (good or weak).
SETTINGS	user can set several key parameters (see paragraph 6.3.1).
LAP MNGMT	shows the geographic coordinates of the place where the camera is positioned; it permits to fix the starting point of GPS lap times (pressing “ Fix ”): once a point is fixed, every time SmartyCam will pass this point, a laptime is registered.
DASH	Info page: shows the data acquired by the camera (if stand alone) or, if slave, by the logger / ECU.

On the top of this page, the functions “**Down**” (to scroll the options), “**Exit**” (to go back to the previous page) and “**Sel**” (to select the desired option) appear.

6.3.1 – “SETTINGS” option

As anticipated, clicking “**SETTINGS**” several options appear:

LANGUAGE	Choose the desired language.
DISPLAY T.out	Switches off the display after 30” while SmartyCam is recording to avoid battery consumption. Registration does not stop.
TIME SETTING	Chooses the time zone and enables/disables daylight saving time. Default setting is Greenwich Time.
CONF LOAD	Imports overlay setting – OVERLAY CONF – from the micro SD to the camera database; this configuration will be used in the following recordings. It imports parameters configuration – SMARTYCONF – too (at present only FILE NAME. AVI).
OVERLAY	Selects a pre-defined overlay configuration among a list previously created through SmartyManager . Each configuration is identified by the name associated through the software.
INFO	Info page showing camera technical data.
VIDEO SET	Sets some Video options useful to maximize lightness and recording quality in case of: SmartyCam use on vehicle roof or onboard (choosing the spot light settings), zoom or not.
AUDIO SET	Adds an external microphone.
ACCEL CALIBR	Calibrates the 3D accelerometer: samples acceleration and tunes SmartyCam frame (paragraph 6.3.1.1.)
AUTO REC	Chooses manual vs. automatic recording: it is useful to start/stop recording automatically when the threshold value of fixed parameters is reached/overcame (paragraph 6.4.2).
AUTO POWEROFF	Enables/disables automatic power-off of the camera after a fixed period of inactivity (paragraph 6.2)

6.3.1.1 – Accelerometer calibration: “ACCEL CALIBR” option

Great attention must be given to the accelerometer calibration procedure, because it impacts on acceleration data accuracy and on correct frame choice.

To set calibration parameters place the camera on a plane surface, switch it on, select “**ACCEL CALIBR**” option and click “**Calibr**”.

To keep correct calibration parameters even once **SmartyCam** is installed on the vehicle, these steps must be followed:

- install the camera;
- select “ACCEL CALIBR”;
- the 2 coordinate axis appear: balance point can be fixed referred to the axes and pressing “**Calibr**” or pressing “**Prev**” and making the image be perfectly ranged and centred: press “**Calibr**” to fix calibration point.

6.4 – How to record videos

It is possible to record images both manually and automatically

Warning: do not remove the Micro SD when SmartyCam is recording, no matter how, or is in “Player” mode (Micro SD icon is red). Otherwise the Micro SD will be permanently damaged.

6.4.1 – Manual recording

Immediately after switching **SmartyCam** on, the display shows the following page:

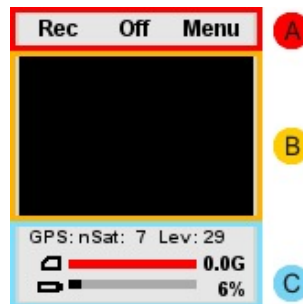

The **keyboard** (“A”) allows to:

- start recording, select “**Rec**”;
- switch **SmartyCam** off, select “**Off**”;
- enter “Menu Status”, select **Menu**”.

The **mid of the page** (“B”)

- the real time image frame is visible;

To start recording, press “**Rec**”: **SmartyCam** will show this page:

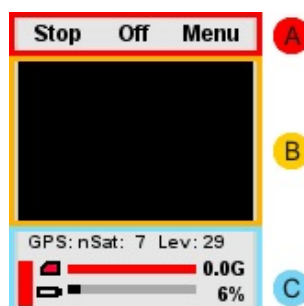

The **keyboard** (“A”) allows to:

- stop recording select “**Stop**”: **SmartyCam** comes back to “Online Status”;
- switch **SmartyCam** off, select “**Off**”;

The **lower part** (“C”) is “**Satellites, Battery and Memory Status**” field.

- When **SmartyCam** is recording a red indicator appears on the left .
- After a pre-defined time of inactivity the display will switch off (see paragraph 6.3.1).

6.4.2 –Automatic recording

It is possible to set the automatic recording option (“**AUTO REC**”), to start/stop recording without manual input:

- **In slave mode** (SmartyCam connected to an AIM logger or ECU Bridge): the logger transmits a start/stop recording input to **SmartyCam**, as soon as it detects RPM's or a speed higher/lower than 10 km/h.
- **In stand alone mode**: recording starts automatically when speed is higher than 10 km/h or acceleration exceeds a threshold value (accelerometer threshold value) to be selected among low (0.2 G), med (0.4 G) and high (0.8 G).

Auto pause: defines a time period (20 sec., 1, 2 or 5 minutes) **SmartyCam** will go on recording even without acceleration or speed. After this period recording process will pause. This function is useful i.e. to go on recording during a pit stop.

6.5 – SmartyCam recording support

SmartyCam kits include a 4 Giga Micro SD but it can support up to 16 Giga.

Warning: use only High Capacity Micro SD like this:



Warning: do not remove the Micro SD when SmartyCam is recording or is in “Player” mode (Micro SD icon is red). Otherwise the Micro SD will be permanently damaged.

Chapter 7– Downloading data and viewing SmartyCam videos

7.1 – Downloading data

SmartyCam can download data via USB (connecting the on board camera to the PC using the cable provided with the kit), or through the micro SD placed in the **SmartyCam** rear, which will have to be inserted in the PC USB port. It is recommended to **use exclusively a 2.0 USB port.**

Warning: when inserting/removing the Micro SD please make sure the flip on the rear is firmly closed.

7.2 – Viewing SmartyCam videos

Videos recorded on **SmartyCam** micro SD are **.avi files with H.264 codec** and can be viewed on PC and on TV.

7.2.1 – Viewing SmartyCam videos on the PC

To view the videos on a PC remove the micro SD from **SmartyCam** (only if Micro SD icon is not red) place it in the reader (or in a portable one connected to the PC like any USB pen drive) and manage it as an USB peripheral.

Videos are in “**Video**” folder.

It is reminded that – to see videos recorded with SmartyCam on the PC – a software compatible with H.264 format is needed. Were such software not available, it is recommended to use “VLC Media Player”, which can be downloaded from www.videolan.org/vlc/.

7.2.2 – Viewing SmartyCam videos on the TV

To view **SmartyCam** videos on the TV ensure that the DVD reader is compatible with “avi.” files with H.264 codec: otherwise the video file needs to be converted in a format compatible with the available reader.

For example it is possible to convert the .avi file in a DVD, using a software like “Nero” version 8 or higher (www.nero.com) or similar software.

If the reader does not have a Micro SD input, it is necessary to copy the video on to a DVD (or CD) using a burning software.

Chapter 8 – SmartyCam Maintenance

SmartyCam does not require any particular maintenance.

Warning: it is strongly recommended not to open the camera.

Periodically check www.SmartyCam.com for software and/or firmware updates; a recommended option is to subscribe to the www.SmartyCam.com newsletter to receive all updates in real time.

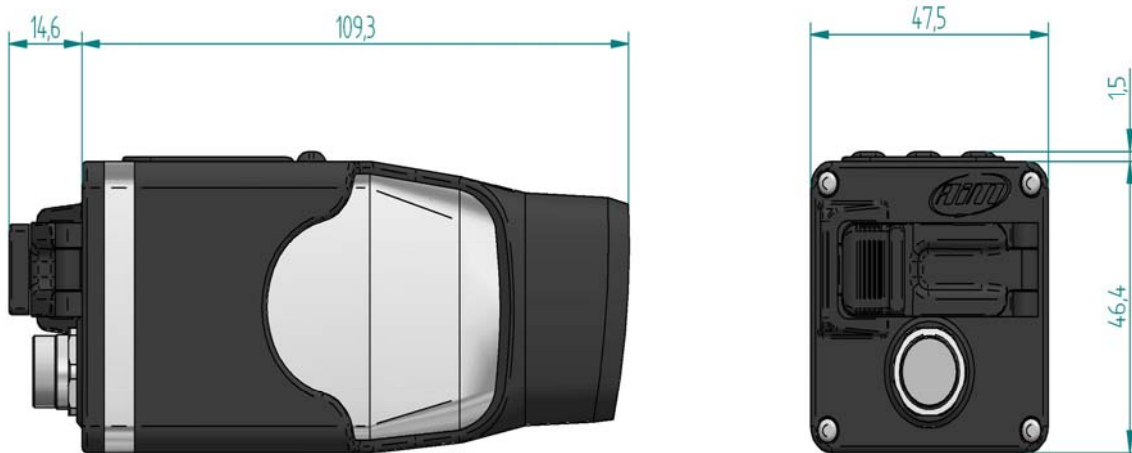

Appendix “A” – Technical specifications



SmartyCam measures (in mm)

Accelerometer	three-axial $\pm 5G$
Internal battery	2.000 mAh 3.7 Volt lithium – rechargeable
Battery charge	via socket/via CAN: 700 mAh max via PC: 700 mAh max
Battery autonomy	until 3 hours with acquisition
Temperature working range	-20°C/+60°C
Display size	128*160 pixel
Weight	210g battery included
Memory	4 Giga (up to 16 Giga supported)
Memory consumption	1 hour recording = about 2 Giga

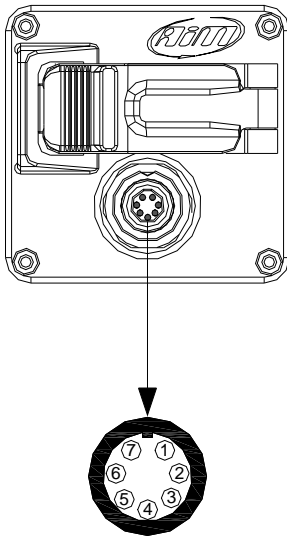
Appendix “B” – SmartyCam Pinout

N. rev. / Rev. N.	Descrizione / Description	Data / Date	Firma / Signature	Contr. da / Ckd. by																
<h1 style="margin: 0;">SMARTYCAM PINOUT</h1> <div style="text-align: center; margin: 20px 0;">  </div> <table border="1" style="margin: 20px auto; border-collapse: collapse;"> <thead> <tr> <th colspan="2" style="text-align: left; padding: 2px;">CAN Bus Binder Pinout Contact insertion view</th> </tr> </thead> <tbody> <tr><td style="text-align: center; padding: 2px;">1</td><td style="padding: 2px;">CAN+</td></tr> <tr><td style="text-align: center; padding: 2px;">2</td><td style="padding: 2px;">GND</td></tr> <tr><td style="text-align: center; padding: 2px;">3</td><td style="padding: 2px;">+Vb</td></tr> <tr><td style="text-align: center; padding: 2px;">4</td><td style="padding: 2px;">CAN-</td></tr> <tr><td style="text-align: center; padding: 2px;">5</td><td style="padding: 2px;">Vbext</td></tr> <tr><td style="text-align: center; padding: 2px;">6</td><td style="padding: 2px;">GND</td></tr> <tr><td style="text-align: center; padding: 2px;">7</td><td style="padding: 2px;">Mic2+</td></tr> </tbody> </table>					CAN Bus Binder Pinout Contact insertion view		1	CAN+	2	GND	3	+Vb	4	CAN-	5	Vbext	6	GND	7	Mic2+
CAN Bus Binder Pinout Contact insertion view																				
1	CAN+																			
2	GND																			
3	+Vb																			
4	CAN-																			
5	Vbext																			
6	GND																			
7	Mic2+																			
Rif. / Ref.	Q.tà/Q.ty	Material / Material		N. articolo / Item N.																
Progettato da / Designed by L.I.	Contr. da / Ckd. by	Approvato da / Approved by	Nome file / File name	Data / Date 12/01/2009																
		Titolo / Title Pinout SmartyCam																		
N. disegno / Drawing N.			Rev. / Rev.	Foglio / Sheet 1 of 1																