



Taipan ECU and Spark software

Tuner Manual

Revision 1.00



INDEX

INDEX	1
1 – Introduction	3
2 – Taipan Description and connections	3
3 – Compatibilities	4
4 – Accessories: Handlebar Switch and UC Bridge	5
4.1 – Handlebar switch	5
4.1.1 How to change Maps:	6
4.1.2 How to apply corrections:	6
4.1.3 How to use the Traction Control:	6
4.1.4 How to activate the Launch Control:	6
4.1.5 Configure the HBS as a Shift Light Module:	7
4.2 – UC Bridge	8
5 – ECU Available Configurations	9
6 – Spark Software	9
6.1 – Software overview	9
6.2 – Menu bar	10
6.2.1 File	10
6.2.2 ECU	13
6.2.3 Configuration	13
6.2.4 Map	14
6.2.5 Live Measures	15
6.2.6 Diagnostics	16
6.2.7 Updates	17
6.2.8 Options	18
7 – Icon bar	19
8 – Project view	20
8.1 – Configuration	20
8.2 Parameters	21
8.2.1 Motorcycle Setup	21
8.2.2 Sensor Plausibility	21
8.2.4 Timers	22
8.2.5 Map switch	23
8.2.6 Launch Control	23
8.2.7 Pre-injection	24
8.3 Strategies	25
8.3.1 Drop sensor	25
8.3.2 Injection strategy	26
8.3.3 Injectors phase strategy	27
8.3.4 Neutral strategy	28
8.3.5 Quick shift	28
8.4 Vb out	29
8.5 CAN Configuration	29
8.5.1 Can parameters	29
8.6 Sensors	30
8.6.1 Spare channel #1 and #2	30
8.6.2 Other sensors	30
8.7 – Maps	30
8.8 Fuel	32
8.8.1 Injection main #1 alpha-n(ms)	32
8.8.2 Injection main speed-density (ms)	33
8.8.3 Injection crank correction (%)	33
8.8.4 Pre-injection (ms)	34
8.8.5 Compensations	34
8.8.6 Injection BAP correction (%)	34
8.8.7 Injection EWT correction (%)	35
8.8.8 Injection IAT correction (%)	35
8.8.9 Injector 1	36
8.8.9.1 Injector 1 battery correction (ms)	36
8.8.10 Injector 2	37
8.8.10.1 Injector 2 battery correction (ms)	37
8.8.10.2 Injector 2 percentage (%)	37
8.8.10.3 Injector 2 phase (phase°)	38
8.8.11 Transient	38

8.8.11.1 Injection opening transient correction.	39
8.8.11.2 Injection closing transient correction.	39
8.9 Ignition	39
8.10 Compensations	40
8.10.1 Ignition BAP correction (Advance °):	40
8.10.2 Ignition EWT correction (Advance °)	40
8.10.3 Ignition IAT correction (Advance °)	41
8.11 Launch control	41
8.11.1 Injection launch control main table (ms)	41
8.11.2 Ignition launch control main table (Advance °)	42
8.12 Quick shift	42
8.12.1 Quick shift cut timetable (ms)	42
8.13 Traction control	43
8.14 – Expansions	43
9 – Data view – special key and visualization	44
9.1 - Table Format	44
9.2 - 2D Format	46
9.3 - 3D Format	46
10 – Live Measures view box	46
11 – Info bar	47
Appendix A – Taipan ECU Part Numbers	49
Appendix B – ECU Taipan dimensions and pinout	50
Appendix C – Harness CAN + Ext power for Solo2	51
DL Appendix D – Main terms	52
Appendix E – Pre-injection	54
Appendix F – Injection crank correction (%)	55
Appendix G – Injection N battery correction	59
Appendix H – Injection BAP correction	60
Appendix I – Transient management	61

1 – Introduction

Taipan is the AiM ECU designed for off-road bikes.



The system includes:

- The Taipan ECU.
- The optional Handlebar Switch.
- The optional USB CAN Bridge.

It is easily installable on most of the off-road bikes, as described in the Chapter 3.

2 – Taipan Description and connections



The Taipan ECU has four connectors:

- The main connector, compatible with most of the off-road bikes
- A CAN connector, to be connected to the Handlebar Switch and to an external datalogger.

- A second CAN connector, to be connected to the UC Bridge, in order to communicate with the PC.
- A fourth connector, to be connected to spare analog inputs and to a possible second injector.

The Pinout is fully described in Appendix B.

3 – Compatibilities

The Taipan ECU, Spark tuning software, and accessories, are compatible with the following model brands and types:

- ✓ GasGas:
 - MC 250F 2021
 - MC 450F 2021
 - FE 501 2020
 - FE 501 2021

- ✓ Honda:
 - CRF 250R 2019
 - CRF 450R 2019
 - CRF 250R 2020
 - CRF 450R 2020
 - CRF 250R 2021
 - CRF 450R 2021

- ✓ Husqvarna:
 - FC 250 2019
 - FC 450 2019
 - FC 250 2020
 - FC 450 2020
 - FC 250 2021
 - FC 450 2021

- ✓ Kawasaki:
 - KX 450F 2019
 - KX 450F 2020
 - KX 250F 2021
 - KX 450F 2021

- ✓ KTM:
 - 250 SX-F 2019
 - 450 SX-F 2019
 - 250 SX-F 2020
 - 450 SX-F 2020
 - 250 SX-F 2021
 - 450 SX-F 2021
 - 500 EXC-F 2020
 - 500 EXC-F 2021

This list will be upgraded with future motorcycle models and brand releases.

4 – Accessories: Handlebar Switch and UC Bridge

Taipan has these accessories:

- Handlebar switch, the fastest way to apply strategies while on the motorcycle.
- USB to CAN dongle used for communication between the Taipan ECU and Spark tuning software.

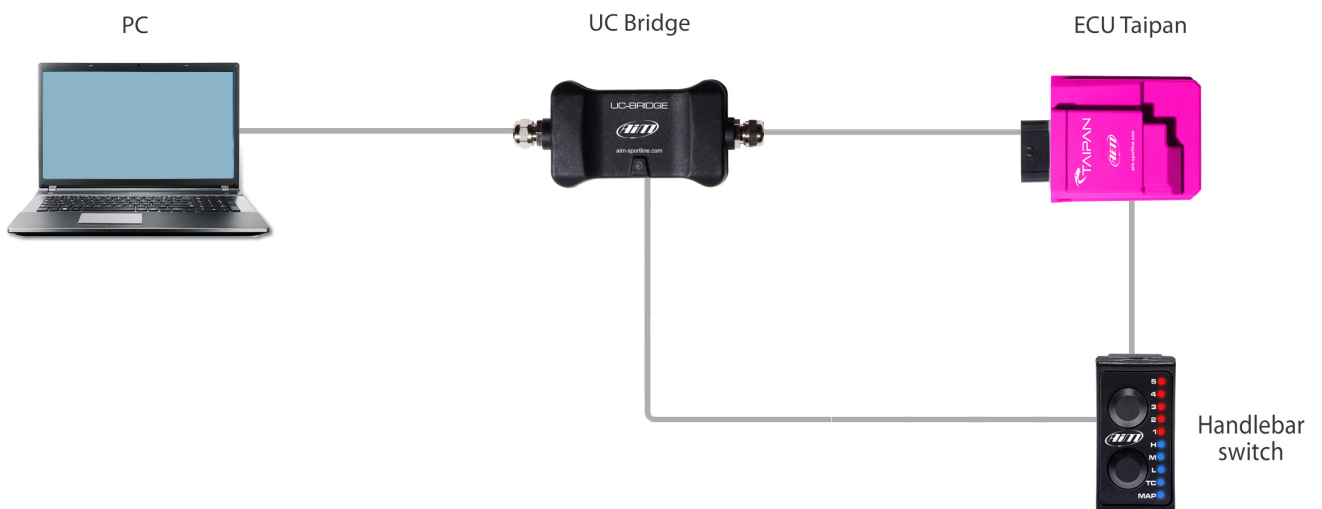

4.1 – Handlebar switch



The Handlebar Switch is the best way for changing the behaviour of your motorcycle; it features 2 pushbuttons and 10 LEDs and manages the following settings:

- 1) Change running map.
- 2) Apply fuel corrections.
- 3) Activate traction control.

4) Activate launch control.

The lower pushbutton is used for changing a feature, while the upper pushbutton is used for choosing one of the possibilities inside the selected feature.

Finally, as covered in section 4.1.5 below, you may use the LEDs on the handlebar switch as a Shift Light Module: in this case, at the desired RPM value, the LEDs will start blinking, helping you in changing gear.

When the ECU is powered ON, the Handlebar Switch will display the running map. The example to the right shows that map 2 is the running map.



4.1.1 How to change Maps:

Keeping the lower button with MAP selected with the lower feature button (shown here in blue), push the upper button for changing the running map. If the selected map is valid, the respective LED will remain lit - it will otherwise return to the previously selected valid map

4.1.2 How to apply corrections:

A Correction is the possibility to get a richer or leaner fuel mixture at different RPM ranges: low, mid, high. The RPM threshold as well as the percentage apply along with the default value, is defined in a proper chapter in this manual (configuration-parameters- map switch – injector trims)

If you want to apply a correction:

- first push the lower pushbutton to select at which RPM range (lower, mid or high) you want to set the correction.
- Then use the upper button to select it, for example (assuming the 3 value is the no-correction value):
 - o Select Level 3 for No Correction
 - o Select Level 4 and 5 for a fatter mixture (5 doubles the percentage chosen).
 - o Select Level 1 and 2 for a leaner mixture (1 doubles the percentage chosen).

4.1.3 How to use the Traction Control:

Traction control is a system that aids in preventing driven wheel spin when excess power is applied.

To activate it:

it, press and hold the lower pushbutton again until the green LED turns OFF.

- 1) keep pushed the lower button until the green LED beside the TC turns ON. If you want to de-activate it, press and hold the lower pushbutton again until the green LED turns OFF.
- 2) With the TC enabled, use the upper pushbutton to select the strength of the Traction Control strategy; with 1 being the minimum and 5 being the maximum.

Please note that the Traction Control must be enabled for the selected Map: this will be done during the ECU Map configuration.

4.1.4 How to activate the Launch Control:

Launch control is an electronic aid to assist riders to accelerate from a standing start.

To activate it, press and hold both the upper and lower pushbuttons until the LED's blink red, indicating that the strategy is engaged.

Please, note that the Launch Control must be enabled in the selected map.

4.1.5 Configure the HBS as a Shift Light Module:

A Shift light module is an array of LEDs that will begin flashing at a defined RPM value, aiding the rider in optimal shift points.

You may use the Handlebar Switch LEDs as a Shift Light after configuring as shown here.

- 1) Please, connect and link the HBS to the UC Bridge through the CAN Connection.

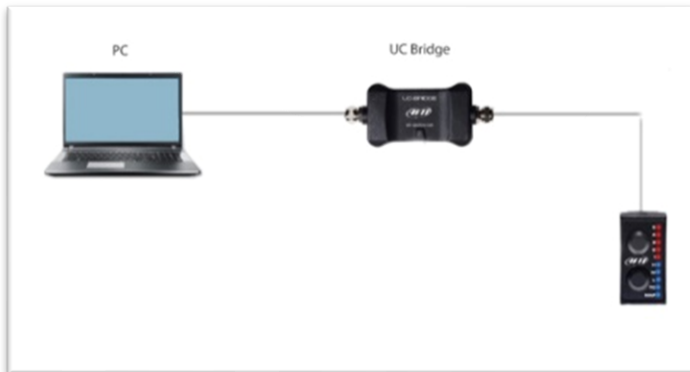

- 2) Open a new project and select the HBS image from the Create New Configuration menu as shown below.

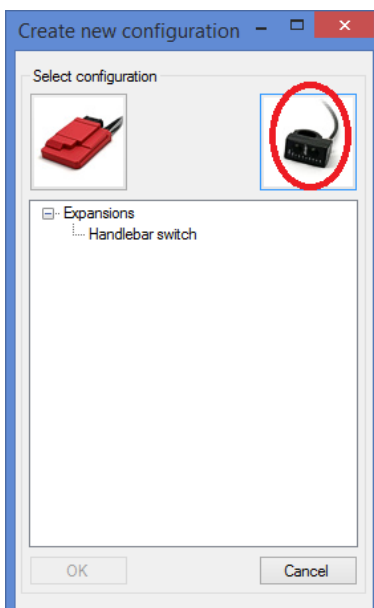

After the selection you will see this project tree:

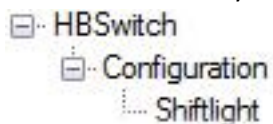

Please, do not forget to click the Connect Icon.

Shift light:

Shift lights Enabled: true or false, to set up if you want to have the shift lights on your HBS or not.
Shift lights RPM threshold: to set up the RPM value at which the LEDs will flash.

After configuring the HBS connect it to the ECU expansion connection.

4.2 – UC Bridge



The **UC Bridge** is the connection between the CAN bus of the ECU and the USB port of your PC, and is available in 2 different licenses:

- **User license:** A Taipan ECU comes with some basic maps that already give you better performances than the stock ones. Some highly professional tuners, all over the world, offer specific maps that may better fit your requirements, managing, for example, different exhaust systems, two injector kits, etc.
You need the UC Bridge for two functions:
 - Transfer new and different maps to your ECU through the User License UC Bridge.
 - Receive from the Taipan ECU the diagnostic information.
- **Tuner license:** With this license the tuner can create maps, configurations, and strategies designed for the rider's motorcycle. The tuner can then flash the ECU directly, or send the file by email to allow the rider to download and flash their own ECU. All while preserving the tuners proprietary work with three layers of protection and security.
-
-
- Then the tuner can flash them directly on the ECU or send them by e-mail to allow the rider to download and install all Maps in the ECU. This manual covers the use of the tuner license.

5 – ECU Available Configurations

Taipan ECU is available in two different configurations:

- **Configured ECU:** An already configured ECU is dedicated to the desired brand and model motorcycle. You may change maps and configurations but cannot change brand or model motorcycle.
- **Blank ECU:** A Blank ECU can be configured for the brand/model motorcycle you desire, simplifying the stock management of the tuners. **Be Careful!** Once you have configured a blank ECU for a dedicated brand and model motorcycle, you have 24 hours for changing the configuration, then you cannot change it anymore: you will anyway be able to modify the maps written into your ECU, but not the brand nor model motorcycle for which you have configured it.

6 – Spark Software



Spark is the AIM software used to configure and calibrate Taipan ECUs. This document explains in detail each available function you can use with this software, with a “tuner” license.

To use the software, you must connect at least the UC Bridge, otherwise you cannot create projects nor use all the functionalities of Spark.

Connecting the UC Bridge and the ECU you can create projects, read projects, write, and flash the ECU.

6.1 – Software overview

When you open the Spark software with UC Bridge connected, the first window appears as in the following picture. The six macro-areas here highlighted will be referred to as indicated here on the right. The following chapters describe every area in detail.

- Black Menu bar (1)
- Red Icon bar (2)
- Green Project view (3)
- Violet Data view (4)
- Blue Live Measures view box (5)
- Orange Info bar (6)

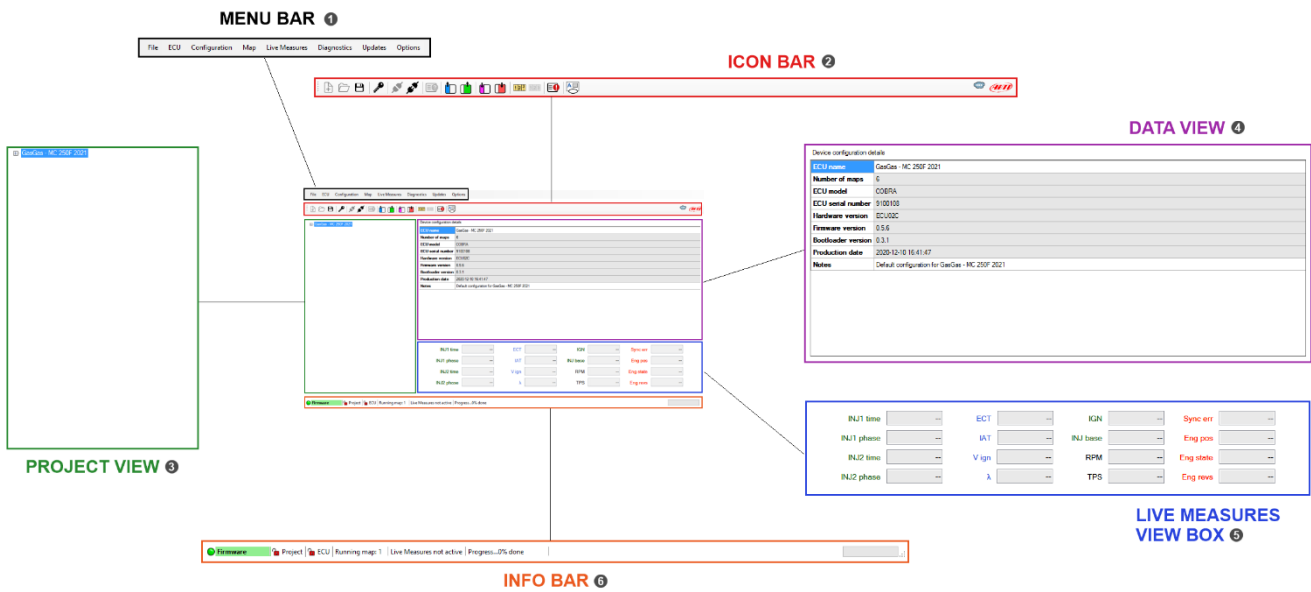

6.2 – Menu bar



This bar features all the available items that allow to manage the project, setup the ECU, monitor data.

Every item includes several functions listed here below.

Please, note that:

- **Connected** is intended to mean “physically connected”: An ECU is “connected” to the PC when connected to the UC Bridge and this last is connected to your PC.
- **Linked** means that the communication between the PC and the device is activated: this is done by clicking on the icon  on the icon bar.

6.2.1 File

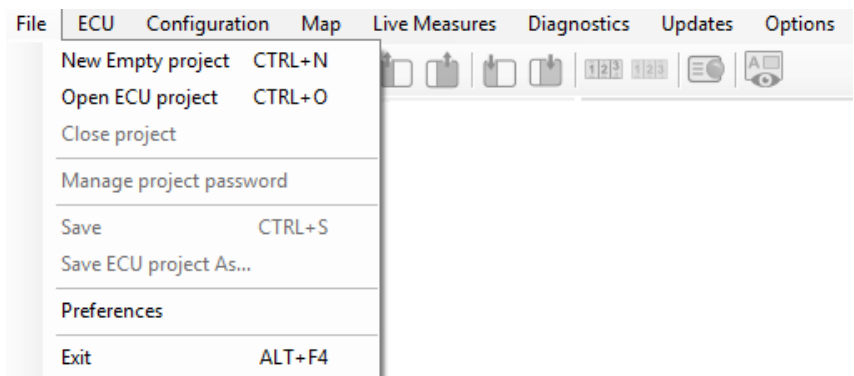

New Empty project: Using this command you can create a new project, that is the sum of configuration, maps, strategies, and other parameters. A list of available motorcycle s will appear after the selection and selecting one of them will enable you to start. It is possible to create a project without connecting the ECU, but the UC Bridge must be connected to your PC.

This is the menu that will appear after the selection of starting a new project, then you can select the motorcycle type or the Handlebar Switch configuration.

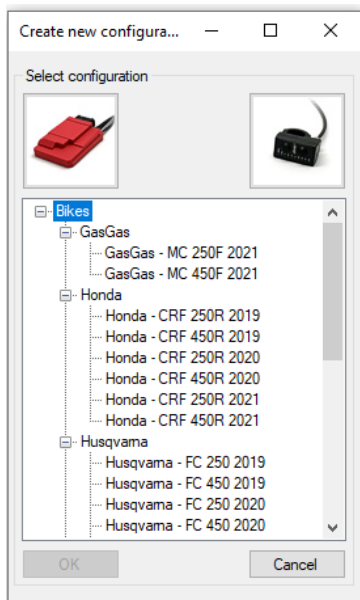

Open ECU project: Open a previously saved project.

Close project: to close the open project.

Manage project password (shortcut icon )

The tuner that has developed a project may protect it with a password: when a protected project is sent to a customer, only who has the password may open it and eventually modify it.

The tuner that develops a project may decide to give the possibility to send exclusively to one or to some ECU(s): in this case, he must create a crypted version of the project, depending upon the SERIAL NUMBER of the ECUs that may receive it.

In the “Manage ECU target list “area you can add or delete a target ECU using its serial number.

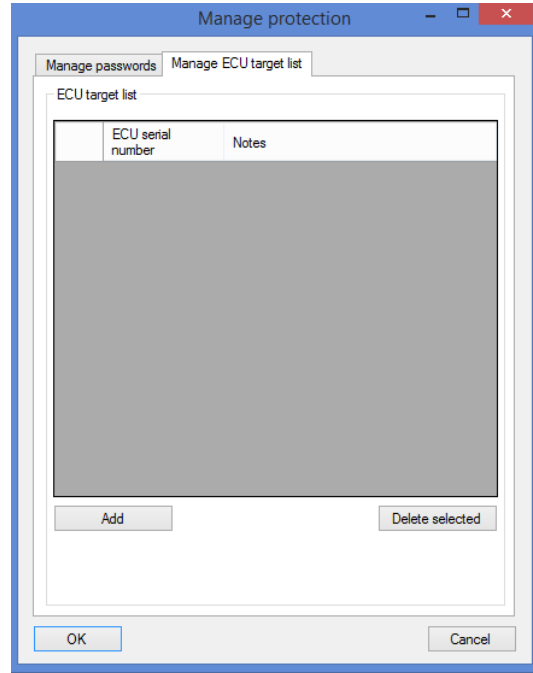
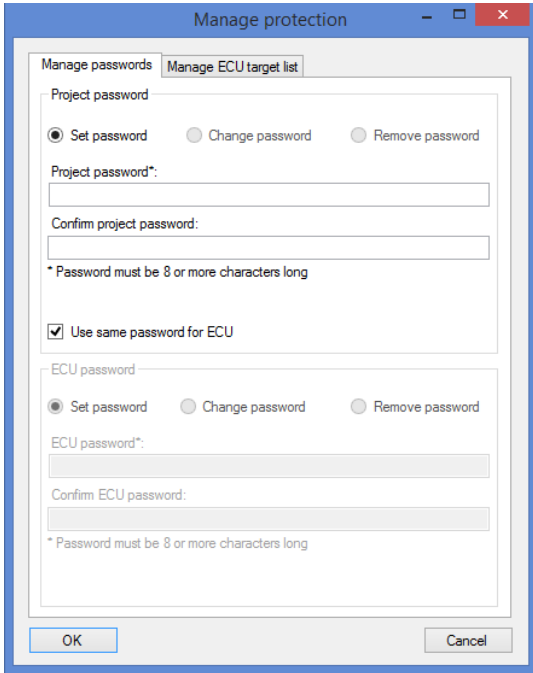

If a password is set when the project is reopened the password will be requested.

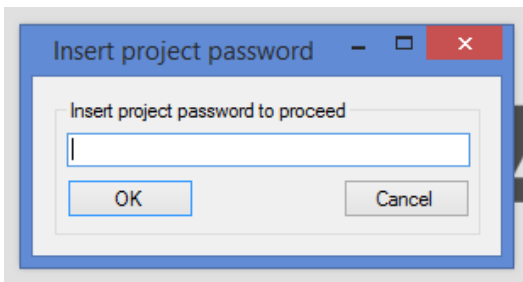

Save: to save the current project.

Save ECU project As...: to save a copy of the current project with a new name.

Preferences: To set up your country measurement units.

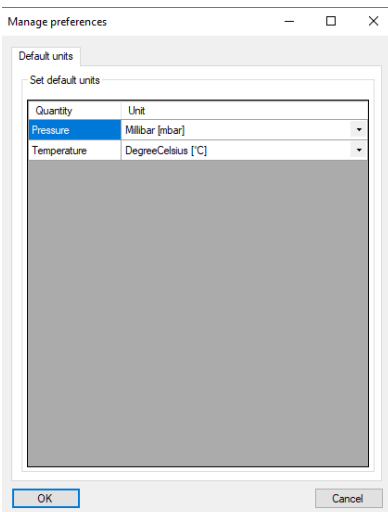

Exit: to close Spark.

6.2.2 ECU

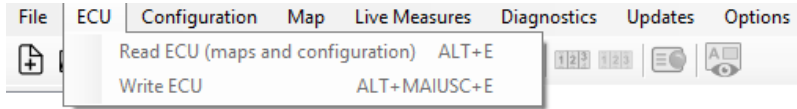

Read ECU (maps and configuration): this command is used to read all the flashed maps and the configuration from the ECU.

To read the ECU maps and configuration you must follow these steps:

- Open a project, selecting the proper motorcycle.
- Connect and link your ECU.
- Read ECU.

Note - the ECU comes with the base map OPEN: if you have the Tuner UC Bridge you may read it and modify as you wish. If the ECU has maps produced by other professional tuners, and reasonably protected by a password, you are required to set the proper password for reading them.

Write ECU: This command is used to flash into the ECU the configuration and maps selected with a dedicated selection menu here below that appears after executing this command.

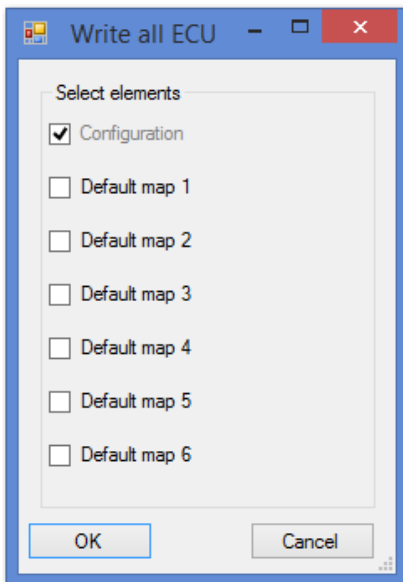

6.2.3 Configuration

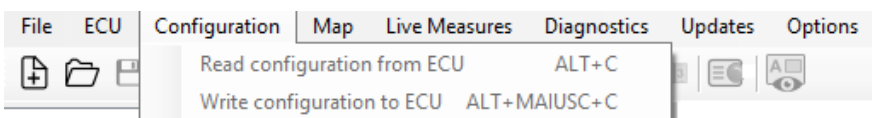

Read configuration from ECU: This command is used to read the configuration from the ECU.

Write configuration to ECU: This command is used to flash the configuration to the ECU.

6.2.4 Map

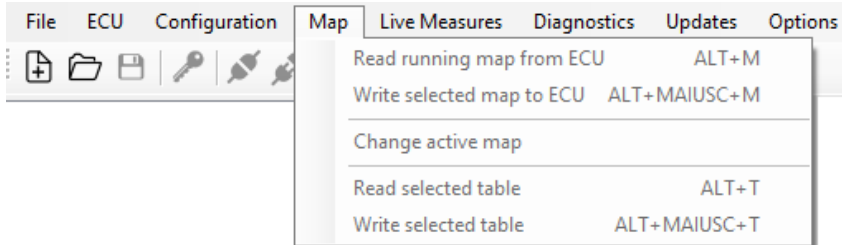

Read running map from ECU: This command is used to read the running map only.

Write selected map to ECU: This command is used to flash the desired map to the ECU.

After having selected this feature, the following image appears:

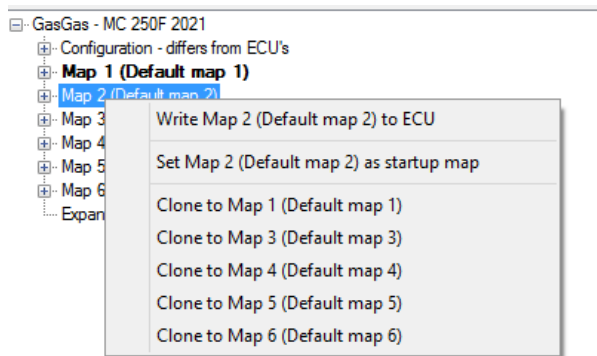

- select the desired map through the right click of your mouse.
- select the menu voice "Write Map".

Finally, you can clone the map on other maps, for future developments.

Change active map: the active map (the map that is now running) can be changed choosing from a dedicated selection menu.

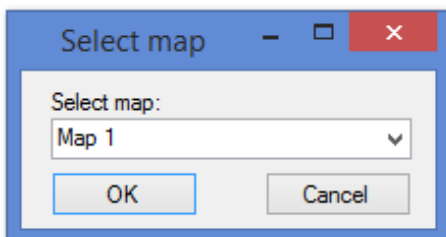

Read selected table: a selected table can be read from the running map.

Write selected table: the selected table can be written to the running map.

6.2.5 Live Measures

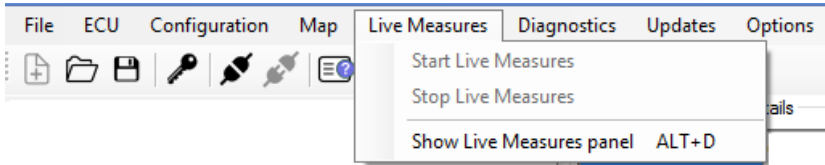

Start Live Measures: this option is used to start the Live Measures in the Live Measures view box, once the project is opened and the ECU is connected.

- Device configuration details

ECU name	GasGas - MC 250F 2021		
Number of maps	6		
ECU model	COBRA		
ECU serial number	9100108		
Hardware version	ECU02C		
Firmware version	0.5.6		
Bootloader version	0.3.1		
Production date	2020-12-10 16:41:47		
Notes	Default configuration for GasGas - MC 250F 2021		

INJ1 time	3.344 ms	ECT	70.0 °C	IGN	9.0 °	Sync err	0 #
INJ1 phase	-92.0 °	IAT	20.0 °C	INJ base	0.760 ms	Eng pos	Seek
INJ2 time	0.000 ms	V ign	0.000 V	RPM	0 rpm	Eng state	Stop
INJ2 phase	-360.0 °	λ	0.000 λ	TPS	0.0 %	Eng revs	0 #

Measures active | Progress...0% done | Live Measures correctly started

Stop Live Measures: stops the live measures in the Live Measures view box.

Hide Live Measures panel: This command hides the Live Measures view box and expands the data view area just above.

Show Live Measures panel: Shows the Live Measures view box.

6.2.6 Diagnostics

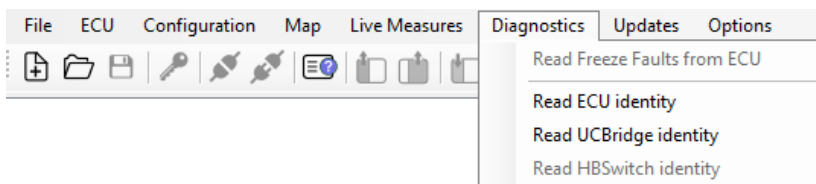

Read Freeze Fault from ECU:

Once the project is opened and the ECU is linked, it is possible to read the diagnostic data in real time or after a session and check the faults of the engine and sensors. Saved faults can be exported in a .csv report file or deleted.

Clicking the command, two tabs appear. The Live faults tab (real time data) and the Freeze faults tab (errors saved). Every fault is reported associated to the hour meter in which it occurred.

Live faults Freeze Faults (hour meter: 00:00:00)

Diagnostics	State
Injector 1 - Open Load	Ok
Injector 1 - Over Current	Ok
Injector 1 - Over Temperature	Ok
Injector 1 - Short to Ground	Ok
Fuel Pump - Open Load	Ok
Fuel Pump - Over Current	Ok
Fuel Pump - Over Temperature	Ok
Fuel Pump - Short to Ground	Ok
MIL led - Open Load	Ok
MIL led - Over Current	Ok
MIL led - Over Temperature	Ok
MIL led - Short to Ground	Ok
MAP sensor signal low	Ok
MAP sensor signal high	Error
TPS sensor signal low	Ok
TPS sensor signal high	Error
Battery voltage signal low	Ok
Battery voltage signal high	Ok
ECT sensor signal low	Ok
ECT sensor signal high	Error
Gear sensor signal low	Ok
Gear sensor signal high	Error
IAT sensor signal low	Ok
IAT sensor signal high	Error
Drop sensor signal low	Ok
Drop sensor signal high	Ok

Live faults Freeze Faults (hour meter: 00:00:00)

Time (hh:mm:ss)	Description
00:00:00	IAT sensor signal high
00:00:00	Gear sensor signal high
00:00:00	ECT sensor signal high
00:00:00	TPS sensor signal high
00:00:00	MAP sensor signal high

If the Live Measures view box is activated, you can visualize the faults in real time. To activate Live Measures, press the Start Live Measure icon

To save the faults in a CSV file press the bottom-right button

To clear the faults list, press the bottom-left button

Read ECU/UC bridge identity: read serial number, firmware version and hardware versions of both ECU and UC bridge. This is important info to maintain the software and devices aligned.

Read Handlebar Switch identity: read serial number, firmware, and configuration from Handlebar Switch (if HB Switch is connected)

Here is the list of the possible sensor errors, coming from the ECU, that can be recognized by Spark (Injector 2 errors are present if there is the injector 2 and it is enabled):

- Injector 1 - Open Load
- Injector 1 - Over Current
- Injector 1 – Over Temperature
- Injector 1 – Short to Ground
- Fuel Pump – Open Load
- Fuel Pump – Over Current
- Fuel Pump – Over temperature
- Fuel Pump – Short to ground
- MIL led – Open load
- Mil led – Over current
- Mil led – Over Temperature
- Mil led – Short to ground
- MAP sensor signal low
- MAP sensor signal high
- TPS sensor signal low
- TPS sensor signal high.
- Battery voltage signal low.
- Battery voltage signal high.
- ECT sensor signal low.
- ECT sensor signal high.
- Gear sensor signal low.
- Gear sensor signal high.
- IAT sensor signal low.
- IAT sensor signal high.
- Drop sensor signal low.
- Drop sensor signal high.

6.2.7 Updates



Update UC Bridge firmware: With project CLOSED and the UC Bridge connected you can update the firmware. First check if an update is present (icon on the right- icon section ). If the update is present you can download it and then install it in this section.

Update ECU Firmware: With project CLOSED and ECU connected you can update the firmware. First check if an update is present (icon on the right- icon section). If the update is present you can download it and then install it in this section.

Update Handlebar Switch Firmware: This section appears only if HB Switch is connected to the UC Bridge.

With project CLOSED and HBS connected you can update the firmware. First check if an update is present (icon on the right- icon section). If the update is present you can download it and then install it.

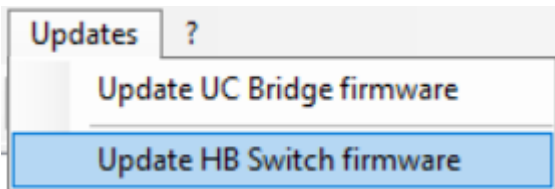

6.2.8 Options

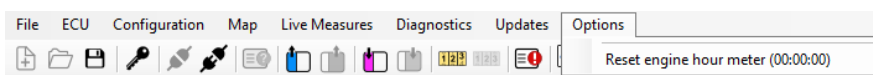

























Reset engine hour meter: This command is used to reset the engine hour meter.

7 – Icon bar

This bar features some shortcut icons for the most common commands. Some of these icons are activated only if the project is open, others when the project is open, and the ECU linked.



	Create a New Project		View diagnostic fault. No fault is detected
	Open Project		View diagnostic fault. One or more faults are detected
	Save Project		Show Live Measure panel
	Manage Project Password		Hide Live Measure panel
	Link to ECU (in order to work on that specific ecu connected)		Web update is present and web connection is detected
	Unlink from ECU		Web update is ready for installation and web connection is detected
	ECU configuration info. Before connecting the ECU, this command lets the user know for which motorcycle model the ECU is configured.		No web update and, web connection is detected
	Read configuration from ECU		downloading web update, and web connection is detected
	Read running Map from ECU		No web update, and web connection is not detected
	Flash configuration to ECU		Web update is present, and web connection is not detected
	Flash running map to ECU		
	Start Live Measure		
	Stop Live Measure		Direct link to AiM web site

8 – Project view

The **Project** is the sum of all the 6 maps and the configuration that describe the behaviour of a bike. In this chapter we explain how to develop and modify a project.

Once the project has been opened, or a new project has been created, the software shows the image below. In the Project tree view the software shows:

- Motorcycle model.
- Configuration.
- The six Maps.
- Expansion: The Handlebar Switch and related parameters.

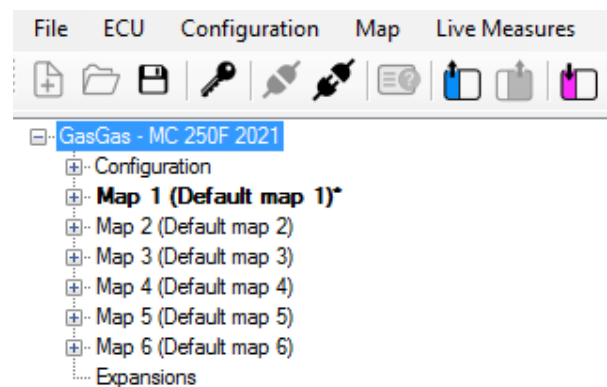

The Project tree can be expanded by pressing the plus symbol, each part includes several submenus that will be explored in the following chapters.

After having connected your ECU, you can find the ECU Info section:

- the motorcycle model
- the serial number
- the hardware and firmware version.
- The production date

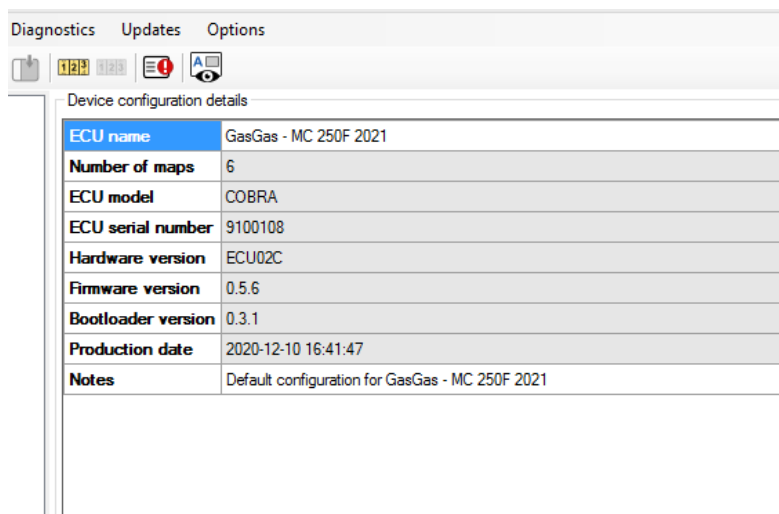

8.1 – Configuration

The configuration section lets you manage all the parameters that are not directly related to the engine performance:

- second injector.
- sensors plausibility.
- kill switch and MIL lamp timers.
- map switch.
- parameters for launch control strategy.
- pre injection.
- RPM limiters.
- drop sensor.
- strategies for injection, injection phase, neutral and quick shift
- Vb out

These features are collected in the following three groups:

- Parameters
- CAN configuration
- Sensors

8.2 Parameters

8.2.1 Motorcycle Setup

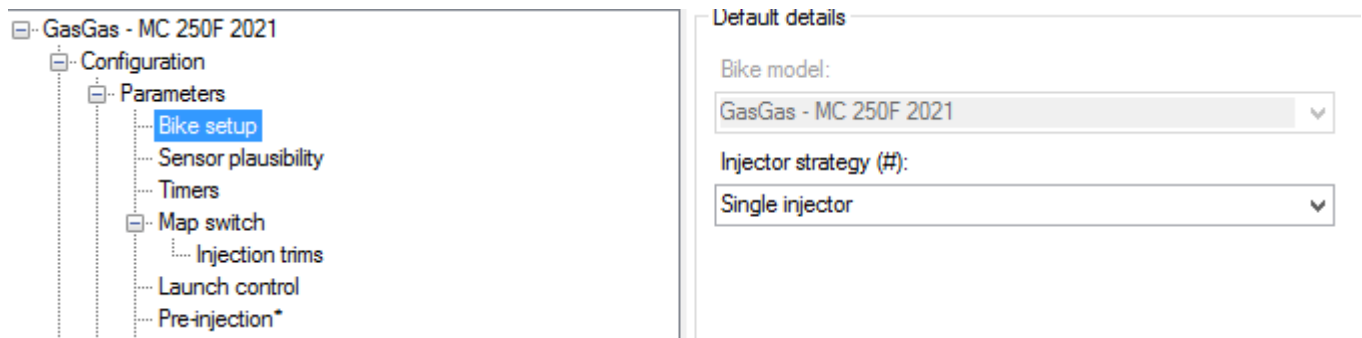

In this section you can be enable the second injector if present.

Please note: after having enabled the second injector, you must define the strategy for activating it, filling the proper injector tables located in the Map section -> Fuel -> Injector (1 and 2)

8.2.2 Sensor Plausibility

Here you can set the acceptability output range of every sensor connected to the ECU.

When a sensor gives an output out of range, the default value is associated to the sensor:

TPS default value: 0.

ECT default value: 70°C.

IAT default value: 20°C.

MAP default value: 1.000 bar

BARO default value: 1.013 bar

- GasGas - MC 250F 2021
 - Configuration
 - Parameters
 - Bike setup
 - Sensor plausibility**
 - Timers
 - Map switch
 - Injection trims
 - Launch control
 - Pre-injection*
 - RPM limiter
 - Strategies
 - Drop sensor
 - Injection strategy
 - Injectors phase strategy
 - Neutral strategy
 - Quickshift
 - Vb out
 - CAN configuration
 - Sensors
 - Map 1 (Default map 1)**
 - Map 2 (Default map 2)
 - Map 3 (Default map 3)
 - Map 4 (Default map 4)
 - Map 5 (Default map 5)
 - Map 6 (Default map 6)
 - Expansions

Sensor plausibility details	
EWT sensor min plausible value (V):	EWT sensor max plausible value (V):
<input type="text" value="0.100"/>	<input type="text" value="4.600"/>
IAT sensor min plausible value (V):	IAT sensor max plausible value (V):
<input type="text" value="0.100"/>	<input type="text" value="4.600"/>
MAP sensor min plausible value (V):	MAP sensor max plausible value (V):
<input type="text" value="0.200"/>	<input type="text" value="4.000"/>
TPS sensor min plausible value (V):	TPS sensor max plausible value (V):
<input type="text" value="0.250"/>	<input type="text" value="4.800"/>
Gear sensor min plausible value (V):	Gear sensor max plausible value (V):
<input type="text" value="0.200"/>	<input type="text" value="4.000"/>
Drop sensor min plausible value (V):	Drop sensor max plausible value (V):
<input type="text" value="0.000"/>	<input type="text" value="5.000"/>
Min map switch plausible value (V):	Max map switch plausible value (V):
<input type="text" value="0.000"/>	<input type="text" value="5.000"/>
Min spare 1 plausible value (V):	Max spare 1 plausible value (V):
<input type="text" value="0.000"/>	<input type="text" value="5.000"/>
Min spare 2 plausible value (V):	Max spare 2 plausible value (V):
<input type="text" value="0.000"/>	<input type="text" value="5.000"/>

Just a few words about the **Min Map Switch range sensor**: this field is intended to define the range of the Min Map Switch, and appears only in the KTM/Husqvarna project, because only these models have the analogue switch input.



8.2.4 Timers

- GasGas - MC 250F 2021
 - Configuration
 - Parameters
 - Bike setup
 - Sensor plausibility
 - Timers**
 - Map switch
 - Injection trims
 - Launch control

Timers details	
MIL test on timer (s):	<input type="text" value="2.000"/>
Kill switch debounce time (s):	<input type="text" value="0.3"/>

Here you can set timers for MIL lamp and kill switch.

- MIL test on timer(s): time that MIL (Malfunction Indicator Lamp) is on for initial check.
- Kill switch debounce time(s): minimum time the kill switch is pressed to activate the motorcycle stop.

8.2.5 Map switch

Injection trims details

Trim injection correction step percentage for low RPM (%):	5	Trim injection correction step percentage for mid RPM (%):	5
Trim injection correction step percentage for high RPM (%):	5	Low RPM trim:	3
Mid RPM trim:	3	High RPM trim:	3
Low to mid RPM threshold (rpm):	6000	Mid to high RPM threshold (rpm):	10000

In this section you can set the configuration parameters of the Handlebar switch.

- Injectors trims:

In this section you can set the percentage steps, the level and the ranges of the fuel corrections that will be set by the Handlebar Switch.

For example, if you set all the step percentages to 2%:

- At Trim injector correction 3, I will not have correction.
- At Trim injector correction 4 and 5, I will have a fuel correction of + 2% or +4%
- At Trim injector correction 2 and 1 I will have a fuel correction of -2% or -4%

Finally, the thresholds between Low and Mid RPM and between Mid and High RPM are set in the dedicated fields.

8.2.6 Launch Control

Launch control details

Maximum engine speed for activation (rpm):	3000	Maximum TPS value for activation (Tps (%)):	5.0
Temporary engine speed limiter (rpm):	10000	Engine speed gap (rpm):	700
Deactivation strategy:	Deactivate LC at pre-defined gear	Deactivation gear (Gear #):	Gear #3

Launch control is an electronic aid to assist riders to accelerate from a standing start.

This strategy has three different states: ENGAGED, ON and OFF. To ENGAGE (that means motorcycle ready to go but still stationary) this strategy the motorcycle needs to be under these conditions:

- The launch control is enabled in the running map.
- The launch control is requested by pushing the launch control button on the Handlebar Switch.
- The RPM must be less than the Maximum RPM value set for launch control activation.
- The bike TPS must be less than the Maximum TPS (threshold) value for launch control activation (%)
- To be in neutral or first gear

Only if these conditions are respected the strategy will be engaged.

When the Launch control is engaged, you may limit the RPM value at a configurable RPM value, set in the field.

- Temporary RPM limiter

The RPM limiter is disabled at the motorcycle starting when the RPM has a drop that you may define in the field:

- Engine speed gap (Rpm)

When the motorcycle begins to move, the Launch Control strategy turns ON and the temporary launch control RPM limiter is activated till when an RPM drop is detected. At this point, the temporary launch control RPM limiter is deactivated, the normal RPM limiter comes back, and the Launch Control table is used.

The Launch Control is deactivated in two different ways:

Deactivate LC after a pre-defined amount of time

Launch control deactivation time - Set the seconds after which LC turns off.

Deactivate LC at pre-defined gear

Launch control deactivation gear - Set the gear where LC turns off.

You can find the launch control tables in Map -> Launch control (injection launch control main table – ignition launch control main table)

8.2.7 Pre-injection

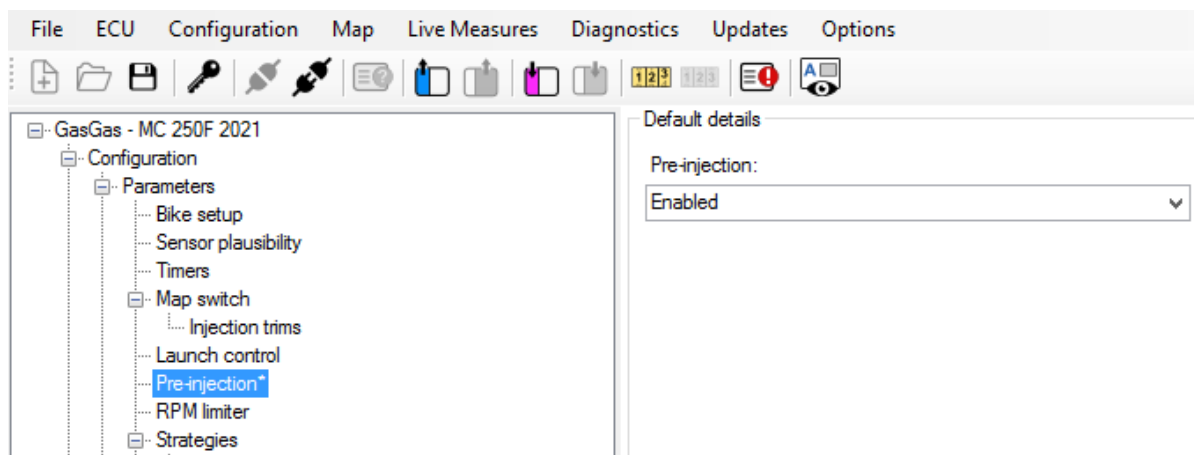

The **pre-injection** is an early amount of fuel injected at the very first crankshaft instants to clean the tubes and improving the fuel passage.

It is possible to enable the pre-injection, while you may set the quantity of injected fuel, in dependence of the water temperature, in the table at:

Map chosen -> Fuel -> Pre-injection.

RPM Limiter

Engine speed limiter (rpm):	Engine speed limiter gap gear (rpm):
14500	50
14500	50
14500	50
14500	50
14500	50
14500	50

Here you may set different RPM threshold per every map.

Beside the limiter values, you may define the RPM gap, in order to define at which RPM value to exit from limiter strategy for each map.

8.3 Strategies

8.3.1 Drop sensor

Drop sensor details	
Drop sensor enabled:	True
Drop sensor kill time (s):	10.0

You can set the parameters for the Drop sensor, the sensor used for evaluating the bike inclination.

- Drop sensor enabled: False/True – to enable the drop sensor signal.
- Drop sensor kill time - if the drop sensor is enabled, select the time to wait before the engine is killed after the drop sensor signal has been triggered.

Please note that this sensor is not present in the Honda bikes, so, in case of Honda projects, this section is not available.

8.3.2 Injection strategy

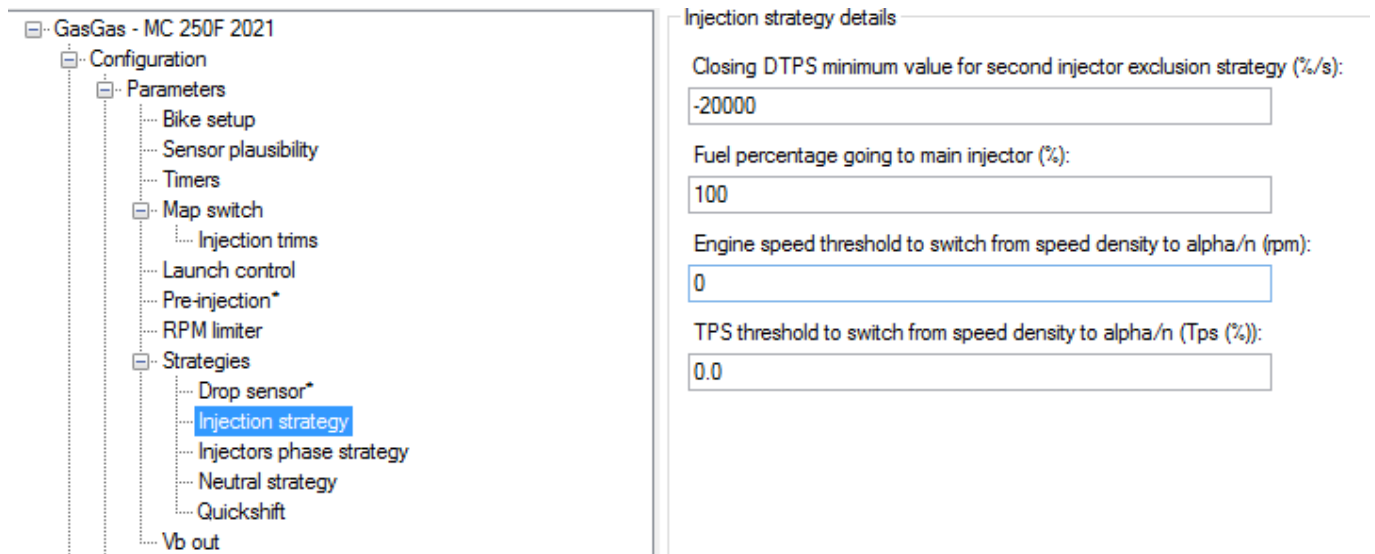

The screenshot shows a configuration tree on the left and a details panel on the right. The tree is expanded to 'Strategies' > 'Injection strategy'. The details panel, titled 'Injection strategy details', contains four input fields:

- Closing DTPS minimum value for second injector exclusion strategy (%/s): -20000
- Fuel percentage going to main injector (%): 100
- Engine speed threshold to switch from speed density to alpha/n (rpm): 0
- TPS threshold to switch from speed density to alpha/n (Tps (%)): 0.0

In this section it is explained how to manage the second injector during a rapid throttle closure.

The second injector is generally positioned above the throttle, in order to have a better air/fuel mixture at high RPM /throttle range.

After a rapid throttle closure, a quantity of fuel may remain nearby the throttle valve, and, at the next throttle rapid opening, may produce a very fat mixture inside the cylinder.

To avoid this problem, with Taipan you can set the fuel percentage that passes through the main injector after a fast TPS closing, helping to keep the fuel/air ratio optimal even in this situation.

The parameters to be set are:

- **Closing DTPS** (TPS closing speed) injector exclusion strategy (%/s): TPS closing speed per second over which to start the strategy.
- **Fuel percentage going to main injector** (%) when the previous condition related to the closure of the DTPS is respected.

To set up the **injector 1** fuel values go to map -> fuel -> injector 1 (injector 1 battery corrections – injector 1 phase)

To set up the **injector 2** fuel values go to map -> fuel -> injector 2 (injector 2 battery corrections - injector 2 percentage - injector 2 phase)

The next two parameters that define the Injection Strategy are intended to decide which table is to be used for establishing the amount of gasoline to be injected:

There are two different ways for calculating the amount of gasoline used in every active phase:

- In dependence upon the amount of aspired air, Speed – density, calculated from the MAP sensor and RPM.
- In dependence upon the throttle angle (alpha) and RPM.

The first method gives a more precise idea of the oxygen available for the combustion, so let us calculate the amount of gasoline necessary for getting the desired lambda value but may be used only when the RPM value is low and the TPS is partially open. Over an RPM threshold and a TPS threshold, that you may define here, it is better to use the second method.

So, when RPM and the TPS are under the set thresholds, the Speed Density/RPM map is used, else the Throttle angle (alpha) / RPM map is used. The parameters to be set here are:

- RPM threshold to switch from speed density to alpha/n table (RPM)
- TPS threshold to switch from speed density to alpha/n table (%)

8.3.3 Injectors phase strategy

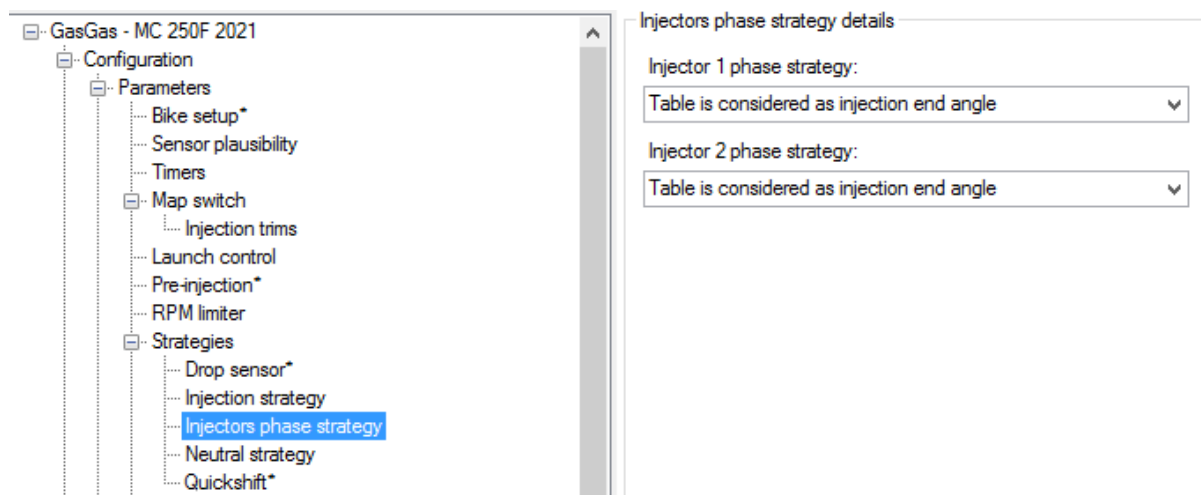

It is possible to set, for every injector, the injection phase as:

- the start of injection or
- the end of injection.

8.3.4 Neutral strategy

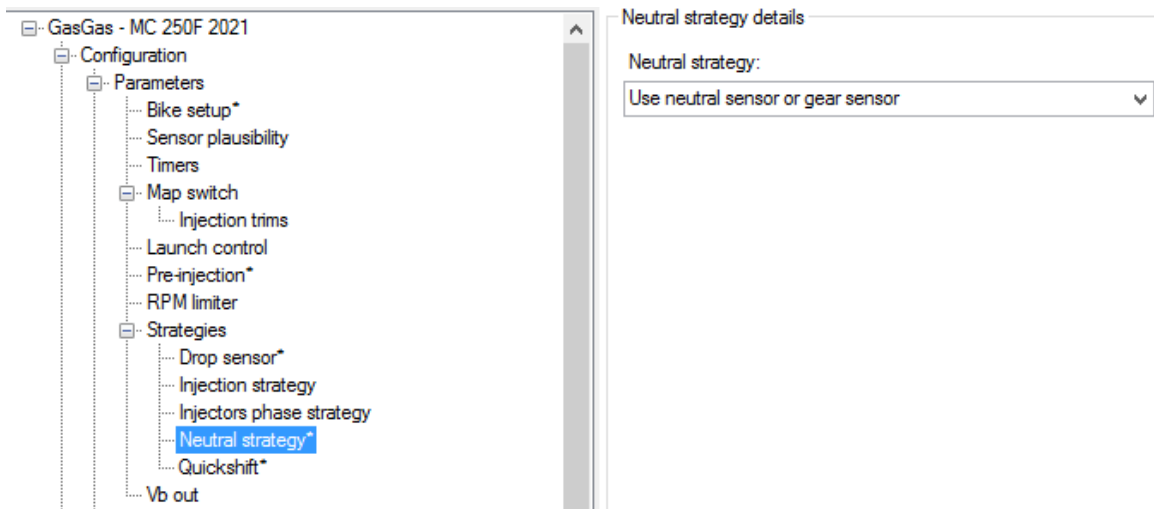

By default, the Map number 6 is dedicated to the neutral strategy.
You can choose how to engage this map in the different ways:

- Strategy OFF: the strategy is disabled.
- Use neutral sensor or gear sensor: if the motorcycle has a neutral or gear sensor and the neutral is detectable, once neutral is engaged the map is automatically changed to map 6, otherwise is changed to the previous default map.
- Use external switch: in this case a bi-stable switch can be plugged in, only once the switch is active the map is changed to map 6.

8.3.5 Quick shift

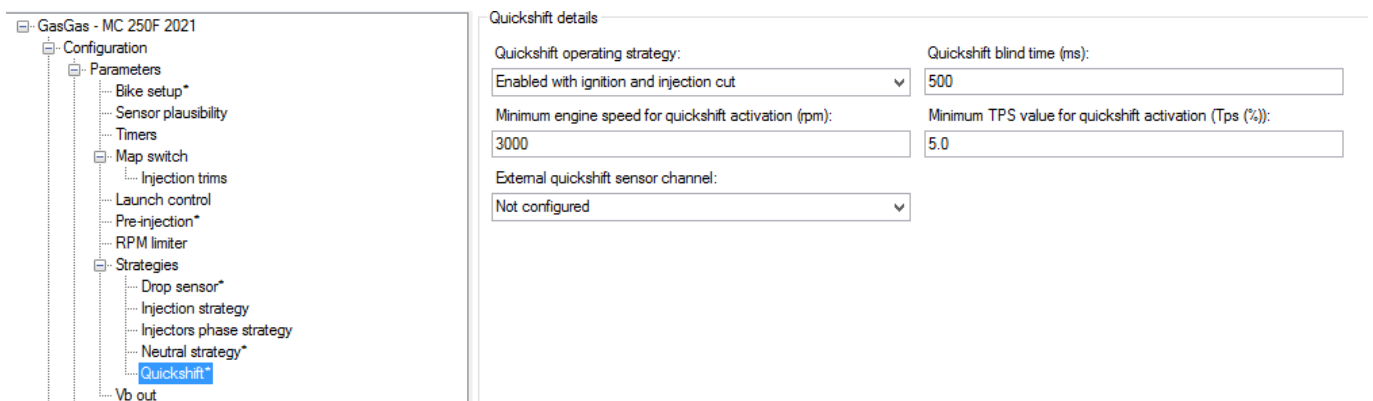

It is possible to set-up the quick shift strategy, in order to reduce the time of power loss between gear changes.
This setting works in combination with a proper quick shift table, to be defined in every map (map -> quick shift)

The Quick Shift may be:

- Quick shift DISABLED.
- Quick shift ENABLED with ignition cut only.
- Quick shift ENABLED with ignition and injection cut.

If the Quick Shift strategy is ENABLED, you must set these parameters:

- Minimum RPM for quick shift activation.
- Minimum TPS value for quick shift activation (%)

Only if TPS and RPM are greater than the thresholds this strategy is active.

- Quick shift blind time (msec): Once the strategy is active for the calculated time from the dedicated table, another shift activation is inhibited for this blind time.
- External quick shift sensor channel: in case your bike must have an external switch, used to read the shift status, connected to one of the two spare inputs of the Taipan ECU.

8.4 Vb out

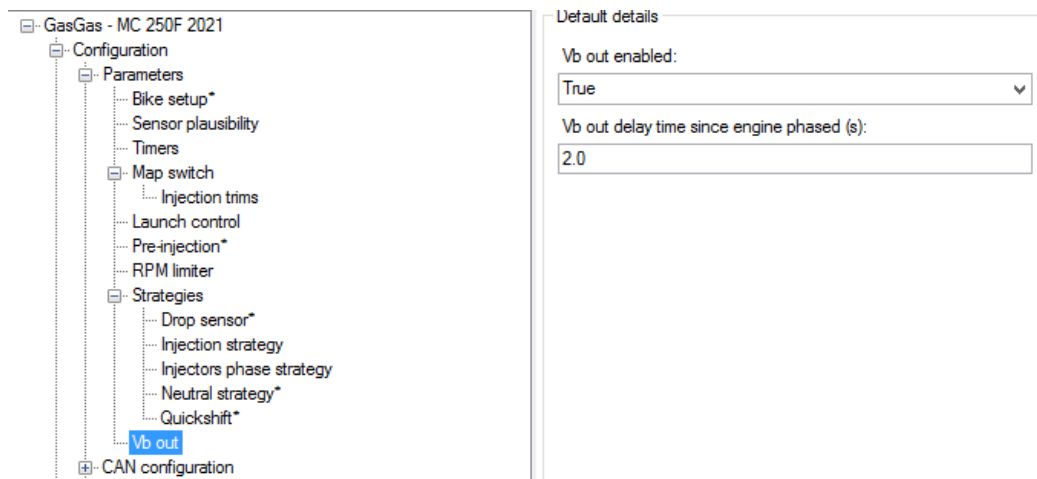

The Taipan ECU can be enabled to generate the Vb (12V power supply) in order to power an external device (i.e., datalogger).

- Vb out enabled: False/True.
- Vb out delay time(s) - the Vb out is generated only if the engine is running and is phased. If these conditions are met, once the delay time expires the ECU starts supplying power externally.

8.5 CAN Configuration

8.5.1 Can parameters

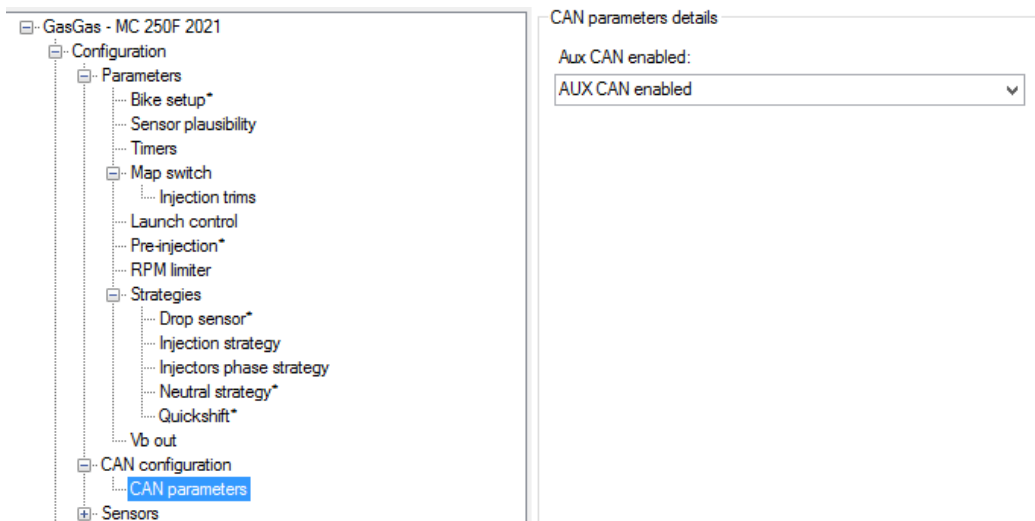

This section is activated when the Expansions section (the last section of the project tree) is set to true. If the section is set to false, you can choose to have a CAN output or not (aux Can enabled / disabled)

8.6 Sensors

In this section it is possible to define external sensors or switches eventually connected to the two auxiliary analogue inputs.

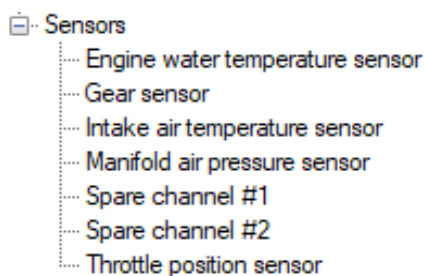

8.6.1 Spare channel #1 and #2

The Taipan ECU offers the possibility to manage two spare sensors. Each of them may be enabled and configured, thanks to a dedicated table with 16 breakpoints. For each entry, the voltage and the corresponding sensor's measure must be defined.

8.6.2 Other sensors

This section is thought to set up on a motorcycle a sensor that is not a stock sensor.

8.7 – Maps

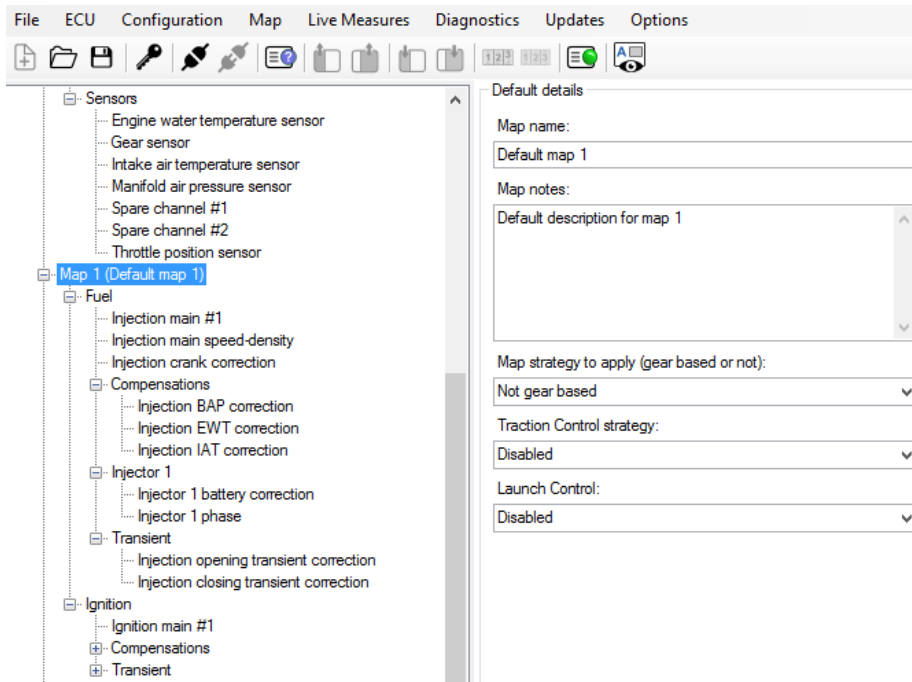

This is the section where the six ECU maps and strategies are defined. Please select a map from the Tree View and look at its details and strategies in the Data View window.

Please note: in the actual chapter the maps, and their meanings, are introduced. In Chapter 9 it will be explained how to manage the entry points.

- **Map strategy to apply (gear based or not):**

The Map Strategy may be:

- Gear based.
- Not Gear based.

In the first case, there is a different main table for injection and ignition per every gear.

- **Traction Control Strategy:**

In case the Traction Control is ENABLED, for every map, the ECU has dedicated parameters, to be described later in this manual.

- **Launch Control:**

In case the Launch Control is ENABLED, for every map, the ECU has a dedicated launch control main table.

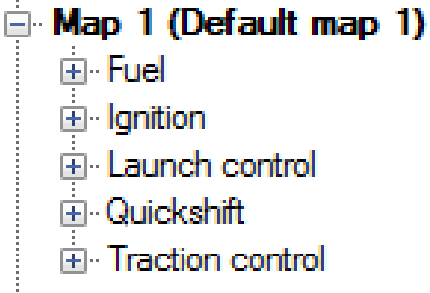

For every map you must set the following tables:

- Fuel
- Ignition
- Launch control (if enabled)
- Quick shift (if enabled)
- Traction control (if enabled)

8.8 Fuel

8.8.1 Injection main #1 alpha-n(ms)

		Map 1 - Fuel.Injection main #1 (ms)																							
Table		2D 3D																							
Tps (%) rpm		250	500	750	1000	1250	1500	1750	2000	2250	2500	2750	3000	3250	3500	3750	4000	4250	4500	4750	5000	5250	5500	5750	
0.0	0.760	0.760	0.760	0.760	0.760	0.760	0.760	0.760	0.760	0.760	0.760	0.760	0.760	0.760	0.760	0.760	0.760	0.760	0.760	0.760	0.760	0.760	0.760	0.760	
2.5	1.180	1.180	1.180	1.180	1.180	1.180	1.180	1.180	1.062	1.053	1.044	1.071	1.062	1.053	0.999	0.963	0.945	0.909	0.872	0.828	0.761	0.709	0.655	0.615	
5.0	1.380	1.380	1.380	1.380	1.380	1.380	1.380	1.380	1.242	1.233	1.233	1.242	1.242	1.224	1.197	1.179	1.159	1.113	1.069	1.014	0.978	0.922	0.877	0.833	
10.0	1.840	1.840	1.840	1.840	1.840	1.840	1.840	1.840	1.860	1.940	1.970	1.930	1.850	1.720	1.640	1.550	1.490	1.440	1.410	1.380	1.360	1.330	1.290	1.250	
25.0	3.020	3.020	3.020	3.020	3.020	3.020	3.010	2.990	3.020	3.210	3.350	3.360	3.180	2.960	2.810	2.700	2.630	2.580	2.530	2.490	2.450	2.380	2.350	2.300	
33.0	3.510	3.510	3.510	3.510	3.510	3.510	3.480	3.440	3.470	3.560	3.570	3.610	3.490	3.120	3.030	2.990	2.950	2.910	2.900	2.890	2.890	2.880	2.900	2.900	
50.0	3.660	3.660	3.660	3.660	3.660	3.660	3.620	3.580	3.620	3.760	3.790	3.840	3.610	3.260	3.090	3.060	3.050	3.030	3.070	3.120	3.220	3.330	3.450	3.530	
66.0	3.750	3.750	3.750	3.750	3.750	3.750	3.710	3.670	3.720	3.880	4.000	3.970	3.670	3.350	3.150	3.100	3.100	3.110	3.130	3.150	3.270	3.390	3.530	3.630	
75.0	3.650	3.650	3.650	3.650	3.570	3.460	3.420	3.380	3.430	3.570	3.640	3.610	3.340	3.180	3.010	2.930	2.930	2.930	2.980	3.020	3.150	3.270	3.400	3.500	
100.0	3.570	3.570	3.570	3.570	3.380	3.260	3.230	3.150	3.230	3.380	3.410	3.390	3.210	3.010	2.860	2.720	2.700	2.680	2.680	2.700	2.860	3.030	3.030	3.030	

X axis: RPM – 64 breakpoints

Y axis: TPS (%) – 10 breakpoints

Entry points: Injection Time (ms)

This map defines the injection time, in ms, in dependence upon the RPM and Throttle position.

In case of gear dependant setting, this table is applied only to the first gear, otherwise is applied for all gears.

The map can also be managed with a 2D view providing a quicker overview of the calibration.

In case the Map Strategy is Gear based, you may also fill the same maps for the other gears.

8.8.2 Injection main speed-density (ms)

kPa\rpm	250	500	750	1000	1250	1500	1750	2000	2250	2500	2750	3000	3250	3500	3750	4000	4250	4500	4750	5000	5250	5500	5750
49.0	0.000	0.000	0.000	0.000	0.000	0.000	0.000	0.000	0.000	0.000	0.000	0.000	0.000	0.000	0.000	0.000	0.000	0.000	0.000	0.000	0.000	0.000	0.000
54.4	0.000	0.000	0.000	0.000	0.000	0.000	0.000	0.000	0.000	0.000	0.000	0.000	0.000	0.000	0.000	0.000	0.000	0.000	0.000	0.000	0.000	0.000	0.000
59.8	0.000	0.000	0.000	0.000	0.000	0.000	0.000	0.000	0.000	0.000	0.000	0.000	0.000	0.000	0.000	0.000	0.000	0.000	0.000	0.000	0.000	0.000	0.000
65.2	0.000	0.000	0.000	0.000	0.000	0.000	0.000	0.000	0.000	0.000	0.000	0.000	0.000	0.000	0.000	0.000	0.000	0.000	0.000	0.000	0.000	0.000	0.000
70.6	0.000	0.000	0.000	0.000	0.000	0.000	0.000	0.000	0.000	0.000	0.000	0.000	0.000	0.000	0.000	0.000	0.000	0.000	0.000	0.000	0.000	0.000	0.000
76.0	0.000	0.000	0.000	0.000	0.000	0.000	0.000	0.000	0.000	0.000	0.000	0.000	0.000	0.000	0.000	0.000	0.000	0.000	0.000	0.000	0.000	0.000	0.000
81.4	0.000	0.000	0.000	0.000	0.000	0.000	0.000	0.000	0.000	0.000	0.000	0.000	0.000	0.000	0.000	0.000	0.000	0.000	0.000	0.000	0.000	0.000	0.000
86.8	0.000	0.000	0.000	0.000	0.000	0.000	0.000	0.000	0.000	0.000	0.000	0.000	0.000	0.000	0.000	0.000	0.000	0.000	0.000	0.000	0.000	0.000	0.000
92.2	0.000	0.000	0.000	0.000	0.000	0.000	0.000	0.000	0.000	0.000	0.000	0.000	0.000	0.000	0.000	0.000	0.000	0.000	0.000	0.000	0.000	0.000	0.000
98.0	0.000	0.000	0.000	0.000	0.000	0.000	0.000	0.000	0.000	0.000	0.000	0.000	0.000	0.000	0.000	0.000	0.000	0.000	0.000	0.000	0.000	0.000	0.000

- X-Axis: RPM
- Y-Axis: MAP (Manifold Air Pressure).
- Entry Point: Injection Time in ms.

This map represents an alternative way to calibrate the ECU: depending upon the manifold air pressure (MAP) sensor, guarantees a better tuning at low RPM and low TPS opening. It is applied when the conditions under the Speed density strategy (Configuration -> Parameters -> Strategies -> Injection strategy) are met, so when RPM and TPS are under the set thresholds.

8.8.3 Injection crank correction (%)

°Fcr	0	1	2	3	4	5	6	7	8	9	10	11	12	13	14	15	16	18	120	300		
-40.0	152.0	155.0	158.0	159.0	159.0	158.5	157.8	154.9	150.8	145.7	140.9	137.7	137.7	137.5	137.5	137.5	137.5	137.5	141.5	145.5	145.5	
-22.0	142.0	145.0	148.0	149.0	149.0	148.5	147.8	144.9	140.8	135.7	130.9	127.7	127.7	127.5	127.5	127.5	127.5	127.5	131.5	135.5	135.5	
-4.0	132.0	135.0	138.0	139.0	139.0	138.5	137.8	134.9	130.8	125.7	120.9	117.7	117.7	117.5	117.5	117.5	117.5	117.5	121.5	125.5	125.5	
14.0	122.0	125.0	128.0	129.0	129.0	128.5	127.8	124.9	120.8	115.7	110.9	107.7	107.7	107.5	107.5	107.5	107.5	107.5	111.5	115.5	115.5	
32.0	109.0	113.0	117.0	119.0	120.0	119.5	117.8	114.9	109.8	103.7	95.9	89.7	88.7	88.5	88.5	88.5	88.5	88.5	96.5	102.5	102.5	
50.0	97.0	101.0	105.0	108.0	110.0	109.5	108.8	104.9	99.8	91.7	84.9	78.7	75.7	74.5	74.5	74.5	74.5	74.5	82.5	88.5	88.5	
68.0	82.0	87.0	92.0	95.0	97.0	97.5	95.8	92.9	86.8	78.7	69.9	64.7	63.7	63.5	63.5	63.5	63.5	63.5	64.5	67.5	69.5	69.5
86.0	53.0	59.0	63.0	66.0	67.0	66.5	63.8	59.9	55.8	50.7	45.9	40.7	35.7	33.5	32.5	32.5	32.5	32.5	33.5	38.5	45.0	
104.0	26.0	28.0	30.0	31.0	31.0	33.0	38.0	42.0	45.0	46.0	43.0	38.0	25.0	15.0	15.0	15.0	15.0	15.0	17.0	23.0	30.0	
122.0	22.0	24.0	27.0	27.0	26.0	27.0	33.0	39.0	43.0	44.0	43.0	38.0	25.0	15.0	15.0	15.0	15.0	15.0	15.0	15.0	30.0	
131.0	22.0	24.0	27.0	27.0	26.0	27.0	33.0	39.0	43.0	44.0	43.0	38.0	25.0	15.0	15.0	15.0	15.0	15.0	15.0	15.0	0.0	
140.0	20.0	21.0	23.0	24.0	22.0	22.0	28.0	34.0	38.0	39.0	38.0	33.0	25.0	15.0	15.0	15.0	15.0	15.0	15.0	15.0	0.0	
149.0	20.0	21.0	23.0	24.0	22.0	22.0	28.0	34.0	38.0	39.0	38.0	33.0	25.0	15.0	15.0	15.0	15.0	15.0	15.0	15.0	0.0	
158.0	10.0	9.0	12.5	10.5	10.5	11.0	14.0	17.0	19.0	19.5	19.0	16.5	12.5	7.5	7.5	7.5	7.5	7.5	7.5	7.5	0.0	
167.0	0.0	0.0	0.0	0.0	0.0	0.0	0.0	0.0	0.0	0.0	0.0	0.0	0.0	0.0	0.0	0.0	0.0	0.0	0.0	0.0	0.0	
176.0	0.0	0.0	0.0	0.0	0.0	0.0	0.0	0.0	0.0	0.0	0.0	0.0	0.0	0.0	0.0	0.0	0.0	0.0	0.0	0.0	0.0	
185.0	0.0	0.0	0.0	0.0	0.0	0.0	0.0	0.0	0.0	0.0	0.0	0.0	0.0	0.0	0.0	0.0	0.0	0.0	0.0	0.0	0.0	
194.0	0.0	0.0	0.0	0.0	0.0	0.0	0.0	0.0	0.0	0.0	0.0	0.0	0.0	0.0	0.0	0.0	0.0	0.0	0.0	0.0	0.0	
203.0	0.0	0.0	0.0	0.0	0.0	0.0	0.0	0.0	0.0	0.0	0.0	0.0	0.0	0.0	0.0	0.0	0.0	0.0	0.0	0.0	0.0	

- X-axis: Number of Revolutions (REV)
- Y-axis Engine Coolant Temperature ECT.
- Entry Point: injection percentual correction to apply at the main injection table.

This table is only applied at the engine crank for the maximum number of revolutions (end point of Revolution X-axis).

This strategy is deeply explained in Appendix F.

8.8.4 Pre-injection (ms)

Map 1 - Fuel.Pre-injection (ms)																
ms\F	5.0	26.6	32.0	37.4	48.2	57.2	68.0	75.2	93.2	102.2	150.8	152.6	179.6	210.2	253.4	285.8
	0.000	0.000	0.000	0.000	0.000	0.000	0.000	0.000	0.000	0.000	0.000	0.000	0.000	0.000	0.000	0.000

- X-axis: Engine Coolant Temperature ECT
- Entry Point: pre-injection durations in ms.

If Pre-injection strategy is enabled, this table is activated by the very first movement of the crankshaft and is applied just before the intervention of all the other tables (injection main / injection crank corrections).

This strategy is deeply explained in Appendix E.

8.8.5 Compensations

All these tables are referred as corrections as to the main injection table.

8.8.6 Injection BAP correction (%)

Table 2D 3D

Map 1 - Fuel.Compensations.Injection BAP correction (%)

%kPa	40.0	45.0	50.0	55.0	60.0	65.0	70.0	75.0	80.0	85.0	90.0	95.0	100.0	105.0	110.0	120.0
	-50.0	-50.0	-50.0	-45.0	-40.0	-37.0	-32.0	-27.0	-22.0	-17.0	-10.0	-5.0	0.0	0.0	5.0	10.0

- X-axis: Barometric pressure
- Entry Point: percentage of fuel correction.

8.8.7 Injection EWT correction (%)

Table 2D 3D

Map 1 - Fuel.Compensations.Injection EWT correction (%)

%°F	-22.0	-4.0	14.0	32.0	50.0	68.0	86.0	104.0	122.0	140.0	158.0	176.0	194.0	212.0	230.0	248.0
	80.0	70.0	65.0	60.0	55.0	40.0	30.0	25.0	18.0	15.0	0.0	0.0	0.0	0.0	0.0	0.0

- X-axis: Engine Water Temperature
- Entry Point: percentage of fuel correction.

8.8.8 Injection IAT correction (%)

Table 2D 3D

Map 1 - Fuel.Compensations.Injection IAT correction (%)

%\°F	-22.0	-4.0	14.0	32.0	50.0	68.0	86.0	104.0	122.0	140.0	158.0	176.0	194.0	194.0	194.0	194.0
	10.0	8.0	6.0	4.0	2.0	1.0	0.0	-1.0	-2.0	-3.0	-4.0	-5.0	-6.0	-7.0	-8.0	-9.0

- X-axis: Intake Air temperature
- Entry Point: percentage of fuel correction.

8.8.9 Injector 1

8.8.9.1 Injector 1 battery correction (ms)

Table 2D 3D

Map 1 - Fuel.Injector 1.Injector 1 battery correction (ms)

ms\V	8.000	8.500	9.000	9.500	10.000	10.500	11.000	11.500	12.000	12.500	13.000	13.500	14.000	14.500	15.000	15.500
	2.500	2.336	2.171	2.007	1.842	1.678	1.513	1.349	1.184	1.020	1.020	1.020	1.000	0.893	0.893	0.893

- X-axis: battery voltage
- Entry Point: injection time offset in ms.

This strategy is deeply explained in Appendix G.

8.8.9.2 Injector 1 phase (phase°)

Map 1 - Fuel.Injector 1.Injector 1 phase (Phase (°))

Tps (%)	500	1000	1500	2000	2500	3000	3500	4000	4500	5000	5500	6000	6500	7000	7500	8000	8500	9000	9500	10000	10500	1100
0.0	-92.0	-92.0	-92.0	-92.0	-92.0	-93.0	-93.0	-93.0	-94.0	-94.0	-94.0	-95.0	-94.0	-95.0	-95.0	-96.0	-96.0	-96.0	-96.0	-97.0	-96.0	-96.0
2.5	-92.0	-92.0	-92.0	-92.0	-92.0	-93.0	-93.0	-93.0	-94.0	-94.0	-94.0	-95.0	-95.0	-94.0	-95.0	-95.0	-96.0	-96.0	-96.0	-97.0	-96.0	-96.0
5.0	-92.0	-92.0	-92.0	-92.0	-92.0	-93.0	-93.0	-93.0	-94.0	-94.0	-94.0	-95.0	-95.0	-94.0	-95.0	-96.0	-95.0	-96.0	-96.0	-95.0	-96.0	-96.0
10.0	-92.0	-92.0	-92.0	-92.0	-92.0	-93.0	-93.0	-94.0	-94.0	-94.0	-95.0	-94.0	-94.0	-95.0	-94.0	-96.0	-96.0	-96.0	-97.0	-97.0	-98.0	-98.0
25.0	-92.0	-92.0	-92.0	-92.0	-93.0	-93.0	-92.0	-92.0	-94.0	-95.0	-98.0	-95.0	-96.0	-97.0	-97.0	-97.0	-97.0	-97.0	-98.0	-97.0	-98.0	-98.0
33.0	-92.0	-92.0	-92.0	-92.0	-93.0	-92.0	-92.0	-92.0	-94.0	-95.0	-95.0	-96.0	-97.0	-101.0	-102.0	-102.0	-103.0	-103.0	-104.0	-104.0	-104.0	-104.0
50.0	-92.0	-92.0	-92.0	-92.0	-93.0	-91.0	-92.0	-92.0	-94.0	-95.0	-95.0	-100.0	-111.0	-121.0	-132.0	-138.0	-143.0	-143.0	-144.0	-144.0	-144.0	-144.0
66.0	-92.0	-92.0	-92.0	-92.0	-93.0	-92.0	-92.0	-92.0	-94.0	-95.0	-105.0	-116.0	-126.0	-137.0	-147.0	-158.0	-164.0	-165.0	-166.0	-166.0	-166.0	-165.0
75.0	-92.0	-92.0	-92.0	-92.0	-92.0	-91.0	-92.0	-92.0	-100.0	-105.0	-115.0	-125.0	-137.0	-146.0	-162.0	-168.0	-169.0	-169.0	-170.0	-171.0	-170.0	-170.0
100.0	-92.0	-92.0	-92.0	-92.0	-93.0	-92.0	-92.0	-92.0	-105.0	-115.0	-125.0	-141.0	-151.0	-162.0	-177.0	-178.0	-179.0	-179.0	-179.0	-179.0	-221.0	-220.0

This table is based on X-axis with RPM and Y-axis with TPS. Depending on the injector operating strategy selected (Configuration -> Parameters -> Strategies) the entry value in this table is the end or the start angle of the injection phase.

X-axis = RPM.

Y-axis = TPS.

Entry Point = end or the start angle of the injection phase.

8.8.10 Injector 2

This section appears only if you have an OEM 2nd injector or if you have selected the proper option in Configuration ->Strategies-> Motorcycle setup)

8.8.10.1 Injector 2 battery correction (ms)

Map 1 - Fuel.Injector 2.Injector 2 battery correction (ms)

ms\V	8.000	8.500	9.000	9.500	10.000	10.500	11.000	11.500	12.000	12.500	13.000	13.500	14.000	14.500	15.000	15.500
8.000	0.000	0.000	0.000	0.000	0.000	0.000	0.000	0.000	0.000	0.000	0.000	0.000	0.000	0.000	0.000	0.000

- X-axis: battery voltage
- Entry Point: injection time offset in ms.

This strategy is deeply explained in Appendix G.

8.8.10.2 Injector 2 percentage (%)

TPs (%)	rpm	250	500	750	1000	1250	1500	1750	2000	2250	2500	2750	3000	3250	3500	3750	4000	4250	4500	4750	5000	5250	5500	5750	6000
0.0	0.0	0.0	0.0	0.0	0.0	0.0	0.0	0.0	0.0	0.0	0.0	0.0	0.0	0.0	0.0	0.0	0.0	0.0	0.0	0.0	0.0	0.0	0.0	0.0	0.0
2.5	0.0	0.0	0.0	0.0	0.0	0.0	0.0	0.0	0.0	0.0	0.0	0.0	0.0	0.0	0.0	0.0	0.0	0.0	0.0	0.0	0.0	0.0	0.0	0.0	0.0
5.0	0.0	0.0	0.0	0.0	0.0	0.0	0.0	0.0	0.0	0.0	0.0	0.0	0.0	0.0	0.0	0.0	0.0	0.0	0.0	0.0	0.0	0.0	0.0	0.0	0.0
10.0	0.0	0.0	0.0	0.0	0.0	0.0	0.0	0.0	0.0	0.0	0.0	0.0	0.0	0.0	0.0	0.0	0.0	0.0	0.0	0.0	0.0	0.0	0.0	0.0	0.0
25.0	0.0	0.0	0.0	0.0	0.0	0.0	0.0	0.0	0.0	0.0	0.0	0.0	0.0	0.0	0.0	0.0	0.0	0.0	0.0	0.0	0.0	0.0	0.0	0.0	0.0
33.0	0.0	0.0	0.0	0.0	0.0	0.0	0.0	0.0	0.0	0.0	0.0	0.0	0.0	0.0	0.0	0.0	0.0	0.0	0.0	0.0	0.0	0.0	0.0	0.0	0.0
50.0	0.0	0.0	0.0	0.0	0.0	0.0	0.0	0.0	0.0	0.0	0.0	0.0	0.0	0.0	0.0	0.0	0.0	0.0	0.0	0.0	0.0	0.0	0.0	0.0	0.0
66.0	0.0	0.0	0.0	0.0	0.0	0.0	0.0	0.0	0.0	0.0	0.0	0.0	0.0	0.0	0.0	0.0	0.0	0.0	0.0	0.0	0.0	0.0	0.0	0.0	0.0
75.0	0.0	0.0	0.0	0.0	0.0	0.0	0.0	0.0	0.0	0.0	0.0	0.0	0.0	0.0	0.0	0.0	0.0	0.0	0.0	0.0	0.0	0.0	0.0	0.0	0.0
100.0	0.0	0.0	0.0	0.0	0.0	0.0	0.0	0.0	0.0	0.0	0.0	0.0	0.0	0.0	0.0	0.0	0.0	0.0	0.0	0.0	0.0	0.0	0.0	0.0	0.0

This table defines the percentual repartition between the two injectors.

X-axis = RPM.

Y-axis = TPS.

Entry Point = percentage of the fuel to the second injector

8.8.10.3 Injector 2 phase (phase°)

TPs (%)	rpm	500	1000	1500	2000	2500	3000	3500	4000	4500	5000	5500	6000	6500	7000	7500	8000	8500	9000	9500	10000	10500	11000	11500
0.0	0.0	0.0	0.0	0.0	0.0	0.0	0.0	0.0	0.0	0.0	0.0	0.0	0.0	0.0	0.0	0.0	0.0	0.0	0.0	0.0	0.0	0.0	0.0	0.0
2.5	0.0	0.0	0.0	0.0	0.0	0.0	0.0	0.0	0.0	0.0	0.0	0.0	0.0	0.0	0.0	0.0	0.0	0.0	0.0	0.0	0.0	0.0	0.0	0.0
5.0	0.0	0.0	0.0	0.0	0.0	0.0	0.0	0.0	0.0	0.0	0.0	0.0	0.0	0.0	0.0	0.0	0.0	0.0	0.0	0.0	0.0	0.0	0.0	0.0
10.0	0.0	0.0	0.0	0.0	0.0	0.0	0.0	0.0	0.0	0.0	0.0	0.0	0.0	0.0	0.0	0.0	0.0	0.0	0.0	0.0	0.0	0.0	0.0	0.0
25.0	0.0	0.0	0.0	0.0	0.0	0.0	0.0	0.0	0.0	0.0	0.0	0.0	0.0	0.0	0.0	0.0	0.0	0.0	0.0	0.0	0.0	0.0	0.0	0.0
33.0	0.0	0.0	0.0	0.0	0.0	0.0	0.0	0.0	0.0	0.0	0.0	0.0	0.0	0.0	0.0	0.0	0.0	0.0	0.0	0.0	0.0	0.0	0.0	0.0
50.0	0.0	0.0	0.0	0.0	0.0	0.0	0.0	0.0	0.0	0.0	0.0	0.0	0.0	0.0	0.0	0.0	0.0	0.0	0.0	0.0	0.0	0.0	0.0	0.0
66.0	0.0	0.0	0.0	0.0	0.0	0.0	0.0	0.0	0.0	0.0	0.0	0.0	0.0	0.0	0.0	0.0	0.0	0.0	0.0	0.0	0.0	0.0	0.0	0.0
75.0	0.0	0.0	0.0	0.0	0.0	0.0	0.0	0.0	0.0	0.0	0.0	0.0	0.0	0.0	0.0	0.0	0.0	0.0	0.0	0.0	0.0	0.0	0.0	0.0
100.0	0.0	0.0	0.0	0.0	0.0	0.0	0.0	0.0	0.0	0.0	0.0	0.0	0.0	0.0	0.0	0.0	0.0	0.0	0.0	0.0	0.0	0.0	0.0	0.0

Depending on the injector operating strategy selected (Configuration -> Parameters -> Strategies -> Injector phase strategy) the entry value in this table is the end or the start angle of the injection phase. This table is made of an X-axis with RPM and Y-axis with TPS.

X-axis = RPM.

Y-axis = TPS.

Entry Point = end or the start angle of the injection phase.

8.8.11 Transient

This function is the one relevant to transient injection mapping tables (transient corrections applied under conditions), these are separated for opening and closing throttle.

This strategy is deeply explained in Appendix I.

8.8.11.1 Injection opening transient correction.

The screenshot shows a configuration tree on the left with 'Injection opening transient correction' highlighted. To the right is a table titled 'Map 1 - Fuel.Transient.Injection opening transient correction'.

Tps (%)	2.0	3.5	4.5	9.0	15.0	20.0	25.0	30.0	35.0	37.5	40.0	45.0	50.0	55.0	60.0	70.0
Opening speed (%/s)	190	300	320	600	850	950	1050	1100	1150	1200	1250	1300	1350	1400	1450	1520
Correction (%)	13.5	14.5	15.4	17.4	26.3	33.2	35.2	36.1	38.0	39.1	39.3	42.8	44.5	46.2	47.1	49.6
Correction time (r)	4	4	4	4	4	4	4	4	5	5	5	5	5	5	5	5

The table is composed by one X-axis with TPS and three rows of entries: **Opening speed (%/s)**, **Correction (%)** and **Correction period (Rev)**. The strategy works as follows: in dependence upon the throttle position (TPS), if its opening speed (dTPS) is over the corresponding value (in the second-row cell), a correction (in the third-row cell) is applied for a number of revolutions (in the fourth row cell).

8.8.11.2 Injection closing transient correction.

The screenshot shows a configuration tree on the left with 'Injection closing transient correction' highlighted. To the right is a table titled 'Map 1 - Fuel.Transient.Injection closing transient correction'.

Tps (%)	20.0	25.0	30.0	32.0	35.0	38.0	43.0	50.0	54.0	57.0	60.0	65.0	70.0	75.0	80.0	85.0
Closing speed (%/s)	-820	-750	-700	-688	-664	-650	-630	-570	-540	-470	-410	-400	-400	-400	-400	-400
Correction (%)	-19.0	-22.0	-27.0	-31.0	-35.0	-46.0	-47.0	-47.0	-48.0	-48.0	-49.0	-51.0	-52.0	-54.0	-51.0	-40.0
Correction time (r)	3	3	3	3	3	3	3	3	3	3	3	1	1	1	2	2

The table is composed by one X-axis with TPS and three rows of entries: **Closing speed (%/s)**, **Correction (%)** and **Correction period (Rev)**. The strategy works as follows: in dependence upon the throttle position (TPS), if its closing speed (dTPS) is below the corresponding value (in the second-row cell), a correction (in the third-row cell) is applied for a number of revolutions (in the fourth row cell).

8.9 Ignition

The screenshot shows a configuration tree for 'Ignition' settings, including 'Ignition main #1' through '#6', 'Compensations', and 'Transient' sub-items.

Ignition main #1 alpha-n (Advance °)

Tps (%)rpm	250	500	750	1000	1250	1500	1750	2000	2250	2500	2750	3000	3250	3500	3750	4000	4250	4500	4750	5000	5250	5500	5750	6000
0.0	9.0	9.0	9.0	9.0	10.4	10.1	10.2	10.5	10.5	10.3	11.0	13.7	17.4	21.7	25.3	30.0	34.3	38.9	41.9	44.8	46.5	47.8	48.4	48.4
2.5	9.0	9.0	9.0	9.0	10.4	10.1	10.3	10.5	10.5	10.3	11.1	12.7	15.3	19.6	25.2	29.9	34.6	38.8	41.8	44.7	46.4	47.7	48.4	48.4
5.0	9.0	9.0	9.0	9.0	15.0	14.8	15.0	15.1	15.0	15.5	15.3	17.3	20.0	25.0	28.8	33.3	38.0	40.3	43.0	44.0	45.1	45.9	46.9	47.4
10.0	9.0	9.0	9.0	9.0	19.7	19.4	19.5	19.7	19.8	19.6	19.7	21.2	23.1	26.1	30.4	34.6	38.0	41.6	43.6	45.4	46.9	48.0	48.7	49.1
25.0	9.0	9.0	9.0	9.0	11.6	11.3	11.5	11.7	11.7	11.5	10.4	12.0	15.1	18.4	21.7	24.5	26.7	29.8	31.6	33.3	35.1	36.5	37.2	37.8
33.0	9.0	9.0	9.0	9.0	10.4	10.1	10.3	10.6	10.5	10.3	10.3	11.1	13.5	15.9	17.8	19.8	20.9	22.6	24.5	26.6	28.3	30.6	31.4	32.0
50.0	9.0	9.0	9.0	9.0	13.2	12.9	13.0	13.2	13.3	13.3	13.8	14.5	17.2	20.0	21.7	22.3	22.4	23.0	23.5	24.0	25.0	25.5	26.1	26.5
66.0	9.0	9.0	9.0	9.0	13.5	13.3	13.4	13.7	13.6	13.7	13.5	15.8	19.1	22.5	25.6	27.1	27.9	29.4	29.9	30.4	30.6	30.3	30.2	30.2
75.0	9.0	9.0	9.0	9.0	11.2	11.1	11.2	11.3	11.4	12.1	13.1	16.1	19.4	22.4	25.2	26.9	27.9	29.8	31.0	32.0	32.2	32.1	31.8	31.8
100.0	9.0	9.0	9.0	9.0	9.1	8.9	9.0	9.1	9.5	10.6	12.3	16.8	20.0	23.1	26.2	29.0	31.4	34.2	34.6	35.4	35.5	35.5	34.5	33.8

This table is based on RPM (X-axis) and TPS (Y-axis), the entry is the ignition advance in degrees (°). In case of gear dependant setting, this table is used only for the first gear, otherwise is applied for all gears.

- Ignition main #2 alpha-n (Advance °)**
- Ignition main #3 alpha-n (Advance °)**
- Ignition main #4 alpha-n (Advance °)**
- Ignition main #5 alpha-n (Advance °)**
- Ignition main #6 alpha-n (Advance °)**

These tables are applied to the corresponding gear (2 to 6), only if the Map strategy to apply is Gear based.

8.10 Compensations

8.10.1 Ignition BAP correction (Advance °):

Advance (°)kPa	40.0	45.0	50.0	55.0	60.0	65.0	70.0	75.0	80.0	85.0	90.0	95.0	100.0	105.0	110.0	120.0
5.0	5.0	5.0	5.0	5.0	5.0	5.0	5.0	4.0	3.0	2.0	1.0	0.0	0.0	0.0	0.0	0.0

This table represents the Barometric Air Pressure contribution to ignition. This table is based on one X-axis with Barometric pressure and the entries are the angle degrees corrections to apply to the main ignition table.

This strategy is deeply explained in Appendix H.

8.10.2 Ignition EWT correction (Advance °)

Map 1 - Ignition.Compensations.Ignition EWT correction (Advance (°))																
Advance (°)\°F	-22.0	-4.0	14.0	32.0	50.0	68.0	86.0	104.0	122.0	140.0	158.0	176.0	194.0	212.0	230.0	248.0
	5.0	5.0	5.0	5.0	5.0	4.0	2.0	2.0	0.0	0.0	0.0	0.0	0.0	0.0	0.0	0.0

This table represents the Engine Water Temperature (EWT) contribution to ignition. This table is based on one X-axis with EWT and the entries are the offset correction of angle degrees to apply to the main ignition table.

8.10.3 Ignition IAT correction (Advance °)

Map 1 - Ignition.Compensations.Ignition IAT correction (Advance (°))																
Advance (°)\°F	-22.0	-4.0	14.0	32.0	50.0	68.0	86.0	104.0	122.0	140.0	158.0	176.0	194.0	194.0	194.0	194.0
	0.0	0.0	0.0	0.0	0.0	0.0	0.0	0.0	0.0	0.0	0.0	0.0	0.0	0.0	0.0	0.0

This table represents the Intake Air Temperature (IAT) contribution to ignition.

X-axis = IAT

Entry Points = angle degrees corrections to apply to the main ignition table.

8.11 Launch control

Launch control is an electronic aid to assist riders to accelerate from a standing start.

This section is viewable only if enabled (click on the map chosen—launch control—enable). You can find the parameters to set the launch control strategy in Configuration -> Parameters -> Launch control.

8.11.1 Injection launch control main table (ms)

GasGas - MC 250F 2021		Table 2D 3D																																																																																																																																																																																																																																																																									
<ul style="list-style-type: none"> Configuration Map 1 (Default map 1)* <ul style="list-style-type: none"> Fuel Ignition <ul style="list-style-type: none"> Ignition main #1 Ignition main #2 Ignition main #3 Ignition main #4 Ignition main #5 Ignition main #6 Compensations Transient Launch control <ul style="list-style-type: none"> Injection launch control main table Ignition launch control main table Quickshift Traction control Map 2 (Default map 2) 		<p style="text-align: center;">Map 1 - Launch control.Injection launch control main table (ms)</p> <table border="1"> <thead> <tr> <th>Tps (%)/rpm</th> <th>250</th> <th>500</th> <th>750</th> <th>1000</th> <th>1250</th> <th>1500</th> <th>1750</th> <th>2000</th> <th>2250</th> <th>2500</th> <th>2750</th> <th>3000</th> <th>3250</th> <th>3500</th> <th>3750</th> <th>4000</th> <th>4250</th> <th>4500</th> <th>4750</th> <th>5000</th> <th>5250</th> <th>5500</th> <th>5750</th> </tr> </thead> <tbody> <tr> <td>0.0</td> <td>0.760</td> <td>0.760</td> <td>0.760</td> <td>0.760</td> <td>0.760</td> <td>0.760</td> <td>0.760</td> <td>0.760</td> <td>0.760</td> <td>0.760</td> <td>0.760</td> <td>0.760</td> <td>0.760</td> <td>0.760</td> <td>0.760</td> <td>0.770</td> <td>0.740</td> <td>0.640</td> <td>0.610</td> <td>0.560</td> <td>0.500</td> <td>0.450</td> <td>0.420</td> </tr> <tr> <td>2.5</td> <td>1.180</td> <td>1.180</td> <td>1.180</td> <td>1.180</td> <td>1.180</td> <td>1.180</td> <td>1.180</td> <td>1.062</td> <td>1.053</td> <td>1.044</td> <td>1.071</td> <td>1.062</td> <td>1.053</td> <td>0.999</td> <td>0.963</td> <td>0.945</td> <td>0.909</td> <td>0.872</td> <td>0.828</td> <td>0.761</td> <td>0.709</td> <td>0.655</td> <td>0.619</td> </tr> <tr> <td>5.0</td> <td>1.380</td> <td>1.380</td> <td>1.380</td> <td>1.380</td> <td>1.380</td> <td>1.380</td> <td>1.380</td> <td>1.242</td> <td>1.233</td> <td>1.233</td> <td>1.242</td> <td>1.242</td> <td>1.224</td> <td>1.197</td> <td>1.179</td> <td>1.159</td> <td>1.113</td> <td>1.069</td> <td>1.014</td> <td>0.978</td> <td>0.922</td> <td>0.877</td> <td>0.832</td> </tr> <tr> <td>10.0</td> <td>1.840</td> <td>1.840</td> <td>1.840</td> <td>1.840</td> <td>1.840</td> <td>1.840</td> <td>1.840</td> <td>1.860</td> <td>1.940</td> <td>1.970</td> <td>1.930</td> <td>1.850</td> <td>1.720</td> <td>1.640</td> <td>1.550</td> <td>1.490</td> <td>1.440</td> <td>1.410</td> <td>1.380</td> <td>1.360</td> <td>1.330</td> <td>1.290</td> <td>1.250</td> </tr> <tr> <td>25.0</td> <td>3.020</td> <td>3.020</td> <td>3.020</td> <td>3.020</td> <td>3.020</td> <td>3.020</td> <td>3.010</td> <td>2.990</td> <td>3.020</td> <td>3.210</td> <td>3.350</td> <td>3.360</td> <td>3.180</td> <td>2.960</td> <td>2.810</td> <td>2.700</td> <td>2.630</td> <td>2.580</td> <td>2.530</td> <td>2.490</td> <td>2.450</td> <td>2.380</td> <td>2.350</td> </tr> <tr> <td>33.0</td> <td>3.510</td> <td>3.510</td> <td>3.510</td> <td>3.510</td> <td>3.510</td> <td>3.510</td> <td>3.480</td> <td>3.440</td> <td>3.470</td> <td>3.560</td> <td>3.570</td> <td>3.610</td> <td>3.490</td> <td>3.120</td> <td>3.030</td> <td>2.990</td> <td>2.950</td> <td>2.910</td> <td>2.900</td> <td>2.890</td> <td>2.880</td> <td>2.900</td> <td>2.900</td> </tr> <tr> <td>50.0</td> <td>3.660</td> <td>3.660</td> <td>3.660</td> <td>3.660</td> <td>3.660</td> <td>3.660</td> <td>3.620</td> <td>3.580</td> <td>3.620</td> <td>3.760</td> <td>3.790</td> <td>3.840</td> <td>3.610</td> <td>3.260</td> <td>3.090</td> <td>3.060</td> <td>3.050</td> <td>3.030</td> <td>3.070</td> <td>3.120</td> <td>3.220</td> <td>3.330</td> <td>3.450</td> </tr> <tr> <td>66.0</td> <td>3.750</td> <td>3.750</td> <td>3.750</td> <td>3.750</td> <td>3.750</td> <td>3.750</td> <td>3.710</td> <td>3.670</td> <td>3.720</td> <td>3.880</td> <td>4.000</td> <td>3.970</td> <td>3.670</td> <td>3.350</td> <td>3.150</td> <td>3.100</td> <td>3.100</td> <td>3.110</td> <td>3.130</td> <td>3.150</td> <td>3.270</td> <td>3.390</td> <td>3.530</td> </tr> <tr> <td>75.0</td> <td>3.650</td> <td>3.650</td> <td>3.650</td> <td>3.650</td> <td>3.570</td> <td>3.460</td> <td>3.420</td> <td>3.380</td> <td>3.430</td> <td>3.570</td> <td>3.640</td> <td>3.610</td> <td>3.340</td> <td>3.180</td> <td>3.010</td> <td>2.930</td> <td>2.930</td> <td>2.930</td> <td>2.980</td> <td>3.020</td> <td>3.150</td> <td>3.270</td> <td>3.400</td> </tr> <tr> <td>100.0</td> <td>3.570</td> <td>3.570</td> <td>3.570</td> <td>3.570</td> <td>3.380</td> <td>3.260</td> <td>3.230</td> <td>3.150</td> <td>3.230</td> <td>3.380</td> <td>3.410</td> <td>3.390</td> <td>3.210</td> <td>3.010</td> <td>2.860</td> <td>2.720</td> <td>2.700</td> <td>2.680</td> <td>2.680</td> <td>2.700</td> <td>2.860</td> <td>3.030</td> <td>3.030</td> </tr> </tbody> </table>		Tps (%)/rpm	250	500	750	1000	1250	1500	1750	2000	2250	2500	2750	3000	3250	3500	3750	4000	4250	4500	4750	5000	5250	5500	5750	0.0	0.760	0.760	0.760	0.760	0.760	0.760	0.760	0.760	0.760	0.760	0.760	0.760	0.760	0.760	0.760	0.770	0.740	0.640	0.610	0.560	0.500	0.450	0.420	2.5	1.180	1.180	1.180	1.180	1.180	1.180	1.180	1.062	1.053	1.044	1.071	1.062	1.053	0.999	0.963	0.945	0.909	0.872	0.828	0.761	0.709	0.655	0.619	5.0	1.380	1.380	1.380	1.380	1.380	1.380	1.380	1.242	1.233	1.233	1.242	1.242	1.224	1.197	1.179	1.159	1.113	1.069	1.014	0.978	0.922	0.877	0.832	10.0	1.840	1.840	1.840	1.840	1.840	1.840	1.840	1.860	1.940	1.970	1.930	1.850	1.720	1.640	1.550	1.490	1.440	1.410	1.380	1.360	1.330	1.290	1.250	25.0	3.020	3.020	3.020	3.020	3.020	3.020	3.010	2.990	3.020	3.210	3.350	3.360	3.180	2.960	2.810	2.700	2.630	2.580	2.530	2.490	2.450	2.380	2.350	33.0	3.510	3.510	3.510	3.510	3.510	3.510	3.480	3.440	3.470	3.560	3.570	3.610	3.490	3.120	3.030	2.990	2.950	2.910	2.900	2.890	2.880	2.900	2.900	50.0	3.660	3.660	3.660	3.660	3.660	3.660	3.620	3.580	3.620	3.760	3.790	3.840	3.610	3.260	3.090	3.060	3.050	3.030	3.070	3.120	3.220	3.330	3.450	66.0	3.750	3.750	3.750	3.750	3.750	3.750	3.710	3.670	3.720	3.880	4.000	3.970	3.670	3.350	3.150	3.100	3.100	3.110	3.130	3.150	3.270	3.390	3.530	75.0	3.650	3.650	3.650	3.650	3.570	3.460	3.420	3.380	3.430	3.570	3.640	3.610	3.340	3.180	3.010	2.930	2.930	2.930	2.980	3.020	3.150	3.270	3.400	100.0	3.570	3.570	3.570	3.570	3.380	3.260	3.230	3.150	3.230	3.380	3.410	3.390	3.210	3.010	2.860	2.720	2.700	2.680	2.680	2.700	2.860	3.030	3.030
Tps (%)/rpm	250	500	750	1000	1250	1500	1750	2000	2250	2500	2750	3000	3250	3500	3750	4000	4250	4500	4750	5000	5250	5500	5750																																																																																																																																																																																																																																																				
0.0	0.760	0.760	0.760	0.760	0.760	0.760	0.760	0.760	0.760	0.760	0.760	0.760	0.760	0.760	0.760	0.770	0.740	0.640	0.610	0.560	0.500	0.450	0.420																																																																																																																																																																																																																																																				
2.5	1.180	1.180	1.180	1.180	1.180	1.180	1.180	1.062	1.053	1.044	1.071	1.062	1.053	0.999	0.963	0.945	0.909	0.872	0.828	0.761	0.709	0.655	0.619																																																																																																																																																																																																																																																				
5.0	1.380	1.380	1.380	1.380	1.380	1.380	1.380	1.242	1.233	1.233	1.242	1.242	1.224	1.197	1.179	1.159	1.113	1.069	1.014	0.978	0.922	0.877	0.832																																																																																																																																																																																																																																																				
10.0	1.840	1.840	1.840	1.840	1.840	1.840	1.840	1.860	1.940	1.970	1.930	1.850	1.720	1.640	1.550	1.490	1.440	1.410	1.380	1.360	1.330	1.290	1.250																																																																																																																																																																																																																																																				
25.0	3.020	3.020	3.020	3.020	3.020	3.020	3.010	2.990	3.020	3.210	3.350	3.360	3.180	2.960	2.810	2.700	2.630	2.580	2.530	2.490	2.450	2.380	2.350																																																																																																																																																																																																																																																				
33.0	3.510	3.510	3.510	3.510	3.510	3.510	3.480	3.440	3.470	3.560	3.570	3.610	3.490	3.120	3.030	2.990	2.950	2.910	2.900	2.890	2.880	2.900	2.900																																																																																																																																																																																																																																																				
50.0	3.660	3.660	3.660	3.660	3.660	3.660	3.620	3.580	3.620	3.760	3.790	3.840	3.610	3.260	3.090	3.060	3.050	3.030	3.070	3.120	3.220	3.330	3.450																																																																																																																																																																																																																																																				
66.0	3.750	3.750	3.750	3.750	3.750	3.750	3.710	3.670	3.720	3.880	4.000	3.970	3.670	3.350	3.150	3.100	3.100	3.110	3.130	3.150	3.270	3.390	3.530																																																																																																																																																																																																																																																				
75.0	3.650	3.650	3.650	3.650	3.570	3.460	3.420	3.380	3.430	3.570	3.640	3.610	3.340	3.180	3.010	2.930	2.930	2.930	2.980	3.020	3.150	3.270	3.400																																																																																																																																																																																																																																																				
100.0	3.570	3.570	3.570	3.570	3.380	3.260	3.230	3.150	3.230	3.380	3.410	3.390	3.210	3.010	2.860	2.720	2.700	2.680	2.680	2.700	2.860	3.030	3.030																																																																																																																																																																																																																																																				

If the Launch control strategy is enabled (Map n -> Launch control -> Enabled) and the corresponding conditions (in Configuration-> Parameters->Launch control) met and a proper switch (like the AiM Handlebar switch or the stock launch control switch if is present on the bike) is present on the motorbike (and the activation button is pressed) this table is applied. This is based on TPS (Y axis) and Rpm (X axis), the entry is the injection time in ms.

8.11.2 Ignition launch control main table (Advance (°))

GasGas - MC 250F 2021		Table 2D 3D																																																																																																																																																																																																																																																																																				
<ul style="list-style-type: none"> Configuration Map 1 (Default map 1)* <ul style="list-style-type: none"> Fuel Ignition <ul style="list-style-type: none"> Ignition main #1 Ignition main #2 Ignition main #3 Ignition main #4 Ignition main #5 Ignition main #6 Compensations Transient Launch control <ul style="list-style-type: none"> Injection launch control main table Ignition launch control main table Quickshift Traction control Map 2 (Default map 2) Map 3 (Default map 3) 		<p style="text-align: center;">Map 1 - Launch control.Ignition launch control main table (Advance (°))</p> <table border="1"> <thead> <tr> <th>Tps (%)/rpm</th> <th>250</th> <th>500</th> <th>750</th> <th>1000</th> <th>1250</th> <th>1500</th> <th>1750</th> <th>2000</th> <th>2250</th> <th>2500</th> <th>2750</th> <th>3000</th> <th>3250</th> <th>3500</th> <th>3750</th> <th>4000</th> <th>4250</th> <th>4500</th> <th>4750</th> <th>5000</th> <th>5250</th> <th>5500</th> <th>5750</th> <th>6000</th> </tr> </thead> <tbody> <tr> <td>0.0</td> <td>9.0</td> <td>9.0</td> <td>9.0</td> <td>9.0</td> <td>10.4</td> <td>10.1</td> <td>10.2</td> <td>10.5</td> <td>10.5</td> <td>10.3</td> <td>11.0</td> <td>13.7</td> <td>17.4</td> <td>21.7</td> <td>25.3</td> <td>30.0</td> <td>34.3</td> <td>38.9</td> <td>41.9</td> <td>44.8</td> <td>46.5</td> <td>47.8</td> <td>48.4</td> <td>48.4</td> </tr> <tr> <td>2.5</td> <td>9.0</td> <td>9.0</td> <td>9.0</td> <td>9.0</td> <td>10.4</td> <td>10.1</td> <td>10.3</td> <td>10.5</td> <td>10.5</td> <td>10.3</td> <td>11.1</td> <td>12.7</td> <td>15.3</td> <td>19.6</td> <td>25.2</td> <td>29.9</td> <td>34.6</td> <td>38.8</td> <td>41.8</td> <td>44.7</td> <td>46.4</td> <td>47.7</td> <td>48.4</td> <td>48.4</td> </tr> <tr> <td>5.0</td> <td>9.0</td> <td>9.0</td> <td>9.0</td> <td>9.0</td> <td>15.0</td> <td>14.8</td> <td>15.0</td> <td>15.1</td> <td>15.0</td> <td>15.5</td> <td>15.3</td> <td>17.3</td> <td>20.0</td> <td>25.0</td> <td>28.8</td> <td>33.3</td> <td>38.0</td> <td>40.3</td> <td>43.0</td> <td>44.0</td> <td>45.1</td> <td>45.9</td> <td>45.9</td> <td>45.9</td> </tr> <tr> <td>10.0</td> <td>9.0</td> <td>9.0</td> <td>9.0</td> <td>9.0</td> <td>19.7</td> <td>19.4</td> <td>19.5</td> <td>19.7</td> <td>19.8</td> <td>19.6</td> <td>19.7</td> <td>21.2</td> <td>23.1</td> <td>26.1</td> <td>30.4</td> <td>34.6</td> <td>38.0</td> <td>41.6</td> <td>43.6</td> <td>45.4</td> <td>46.9</td> <td>48.0</td> <td>48.7</td> <td>48.7</td> </tr> <tr> <td>25.0</td> <td>9.0</td> <td>9.0</td> <td>9.0</td> <td>9.0</td> <td>11.6</td> <td>11.3</td> <td>11.5</td> <td>11.7</td> <td>11.7</td> <td>11.5</td> <td>10.4</td> <td>12.0</td> <td>15.1</td> <td>18.4</td> <td>21.7</td> <td>24.5</td> <td>26.7</td> <td>29.8</td> <td>31.6</td> <td>33.3</td> <td>35.1</td> <td>36.5</td> <td>37.2</td> <td>37.2</td> </tr> <tr> <td>33.0</td> <td>9.0</td> <td>9.0</td> <td>9.0</td> <td>9.0</td> <td>10.4</td> <td>10.1</td> <td>10.3</td> <td>10.6</td> <td>10.5</td> <td>10.3</td> <td>10.3</td> <td>11.1</td> <td>13.5</td> <td>15.9</td> <td>17.8</td> <td>19.8</td> <td>20.9</td> <td>22.6</td> <td>24.5</td> <td>26.6</td> <td>28.3</td> <td>30.6</td> <td>31.4</td> <td>31.4</td> </tr> <tr> <td>50.0</td> <td>9.0</td> <td>9.0</td> <td>9.0</td> <td>9.0</td> <td>13.2</td> <td>12.9</td> <td>13.0</td> <td>13.2</td> <td>13.3</td> <td>13.3</td> <td>13.8</td> <td>14.5</td> <td>17.2</td> <td>20.0</td> <td>21.7</td> <td>22.3</td> <td>22.4</td> <td>23.0</td> <td>23.5</td> <td>24.0</td> <td>25.0</td> <td>25.5</td> <td>26.1</td> <td>26.1</td> </tr> <tr> <td>66.0</td> <td>9.0</td> <td>9.0</td> <td>9.0</td> <td>9.0</td> <td>13.5</td> <td>13.3</td> <td>13.4</td> <td>13.7</td> <td>13.6</td> <td>13.7</td> <td>13.5</td> <td>15.8</td> <td>19.1</td> <td>22.5</td> <td>25.6</td> <td>27.1</td> <td>27.9</td> <td>29.4</td> <td>29.9</td> <td>30.4</td> <td>30.6</td> <td>30.3</td> <td>30.2</td> <td>30.2</td> </tr> <tr> <td>75.0</td> <td>9.0</td> <td>9.0</td> <td>9.0</td> <td>9.0</td> <td>11.2</td> <td>11.1</td> <td>11.2</td> <td>11.3</td> <td>11.4</td> <td>12.1</td> <td>13.1</td> <td>16.1</td> <td>19.4</td> <td>22.4</td> <td>25.2</td> <td>26.9</td> <td>27.9</td> <td>29.8</td> <td>31.0</td> <td>32.0</td> <td>32.2</td> <td>32.1</td> <td>31.8</td> <td>31.8</td> </tr> <tr> <td>100.0</td> <td>9.0</td> <td>9.0</td> <td>9.0</td> <td>9.0</td> <td>9.1</td> <td>8.9</td> <td>9.0</td> <td>9.1</td> <td>9.5</td> <td>10.6</td> <td>12.3</td> <td>16.8</td> <td>20.0</td> <td>23.1</td> <td>26.2</td> <td>29.0</td> <td>31.4</td> <td>34.2</td> <td>34.6</td> <td>35.4</td> <td>35.5</td> <td>35.5</td> <td>34.5</td> <td>34.5</td> </tr> </tbody> </table>		Tps (%)/rpm	250	500	750	1000	1250	1500	1750	2000	2250	2500	2750	3000	3250	3500	3750	4000	4250	4500	4750	5000	5250	5500	5750	6000	0.0	9.0	9.0	9.0	9.0	10.4	10.1	10.2	10.5	10.5	10.3	11.0	13.7	17.4	21.7	25.3	30.0	34.3	38.9	41.9	44.8	46.5	47.8	48.4	48.4	2.5	9.0	9.0	9.0	9.0	10.4	10.1	10.3	10.5	10.5	10.3	11.1	12.7	15.3	19.6	25.2	29.9	34.6	38.8	41.8	44.7	46.4	47.7	48.4	48.4	5.0	9.0	9.0	9.0	9.0	15.0	14.8	15.0	15.1	15.0	15.5	15.3	17.3	20.0	25.0	28.8	33.3	38.0	40.3	43.0	44.0	45.1	45.9	45.9	45.9	10.0	9.0	9.0	9.0	9.0	19.7	19.4	19.5	19.7	19.8	19.6	19.7	21.2	23.1	26.1	30.4	34.6	38.0	41.6	43.6	45.4	46.9	48.0	48.7	48.7	25.0	9.0	9.0	9.0	9.0	11.6	11.3	11.5	11.7	11.7	11.5	10.4	12.0	15.1	18.4	21.7	24.5	26.7	29.8	31.6	33.3	35.1	36.5	37.2	37.2	33.0	9.0	9.0	9.0	9.0	10.4	10.1	10.3	10.6	10.5	10.3	10.3	11.1	13.5	15.9	17.8	19.8	20.9	22.6	24.5	26.6	28.3	30.6	31.4	31.4	50.0	9.0	9.0	9.0	9.0	13.2	12.9	13.0	13.2	13.3	13.3	13.8	14.5	17.2	20.0	21.7	22.3	22.4	23.0	23.5	24.0	25.0	25.5	26.1	26.1	66.0	9.0	9.0	9.0	9.0	13.5	13.3	13.4	13.7	13.6	13.7	13.5	15.8	19.1	22.5	25.6	27.1	27.9	29.4	29.9	30.4	30.6	30.3	30.2	30.2	75.0	9.0	9.0	9.0	9.0	11.2	11.1	11.2	11.3	11.4	12.1	13.1	16.1	19.4	22.4	25.2	26.9	27.9	29.8	31.0	32.0	32.2	32.1	31.8	31.8	100.0	9.0	9.0	9.0	9.0	9.1	8.9	9.0	9.1	9.5	10.6	12.3	16.8	20.0	23.1	26.2	29.0	31.4	34.2	34.6	35.4	35.5	35.5	34.5	34.5
Tps (%)/rpm	250	500	750	1000	1250	1500	1750	2000	2250	2500	2750	3000	3250	3500	3750	4000	4250	4500	4750	5000	5250	5500	5750	6000																																																																																																																																																																																																																																																														
0.0	9.0	9.0	9.0	9.0	10.4	10.1	10.2	10.5	10.5	10.3	11.0	13.7	17.4	21.7	25.3	30.0	34.3	38.9	41.9	44.8	46.5	47.8	48.4	48.4																																																																																																																																																																																																																																																														
2.5	9.0	9.0	9.0	9.0	10.4	10.1	10.3	10.5	10.5	10.3	11.1	12.7	15.3	19.6	25.2	29.9	34.6	38.8	41.8	44.7	46.4	47.7	48.4	48.4																																																																																																																																																																																																																																																														
5.0	9.0	9.0	9.0	9.0	15.0	14.8	15.0	15.1	15.0	15.5	15.3	17.3	20.0	25.0	28.8	33.3	38.0	40.3	43.0	44.0	45.1	45.9	45.9	45.9																																																																																																																																																																																																																																																														
10.0	9.0	9.0	9.0	9.0	19.7	19.4	19.5	19.7	19.8	19.6	19.7	21.2	23.1	26.1	30.4	34.6	38.0	41.6	43.6	45.4	46.9	48.0	48.7	48.7																																																																																																																																																																																																																																																														
25.0	9.0	9.0	9.0	9.0	11.6	11.3	11.5	11.7	11.7	11.5	10.4	12.0	15.1	18.4	21.7	24.5	26.7	29.8	31.6	33.3	35.1	36.5	37.2	37.2																																																																																																																																																																																																																																																														
33.0	9.0	9.0	9.0	9.0	10.4	10.1	10.3	10.6	10.5	10.3	10.3	11.1	13.5	15.9	17.8	19.8	20.9	22.6	24.5	26.6	28.3	30.6	31.4	31.4																																																																																																																																																																																																																																																														
50.0	9.0	9.0	9.0	9.0	13.2	12.9	13.0	13.2	13.3	13.3	13.8	14.5	17.2	20.0	21.7	22.3	22.4	23.0	23.5	24.0	25.0	25.5	26.1	26.1																																																																																																																																																																																																																																																														
66.0	9.0	9.0	9.0	9.0	13.5	13.3	13.4	13.7	13.6	13.7	13.5	15.8	19.1	22.5	25.6	27.1	27.9	29.4	29.9	30.4	30.6	30.3	30.2	30.2																																																																																																																																																																																																																																																														
75.0	9.0	9.0	9.0	9.0	11.2	11.1	11.2	11.3	11.4	12.1	13.1	16.1	19.4	22.4	25.2	26.9	27.9	29.8	31.0	32.0	32.2	32.1	31.8	31.8																																																																																																																																																																																																																																																														
100.0	9.0	9.0	9.0	9.0	9.1	8.9	9.0	9.1	9.5	10.6	12.3	16.8	20.0	23.1	26.2	29.0	31.4	34.2	34.6	35.4	35.5	35.5	34.5	34.5																																																																																																																																																																																																																																																														

If the Launch control strategy is enabled (Map n -> Launch control -> Enabled), the corresponding conditions (in Configuration -> Parameters -> Launch control) are met and a proper switch (like the AiM Handlebar switch or the stock launch control switch if is present on the bike) is present on the motorcycle this table is applied. This table is based on TPS (Y axis) and Rpm (X axis) and the entry is the offset correction of angle degrees.

8.12 Quick shift

Quick shift is a strategy that works by reducing time of power loss between gear changes.

This section is viewable only if enabled (click on Configuration -> Strategies -> Quick shift -> Enable). You can find the parameters to set the Quick shift strategy in Configuration -> Parameters -> Strategies -> Quick shift.

8.12.1 Quick shift cut timetable (ms)

Table		2D	3D																																																																																																																																																																																																																																																											
<div style="display: flex;"> <div style="flex: 1;"> <ul style="list-style-type: none"> GasGas - MC 250F 2021 <ul style="list-style-type: none"> Configuration <ul style="list-style-type: none"> Parameters CAN configuration Sensors Map 1 (Default map 1)* <ul style="list-style-type: none"> Fuel Ignition Launch control Quickshift <ul style="list-style-type: none"> Quickshift cut time table Traction control <ul style="list-style-type: none"> Map 2 (Default map 2) Map 3 (Default map 3) Map 4 (Default map 4) Map 5 (Default map 5) Map 6 (Default map 6) Expansions </div> <div style="flex: 2;"> <table border="1"> <thead> <tr> <th colspan="20">Map 1 - Quickshift.Quickshift cut time table (ms)</th> </tr> <tr> <th>Tps (%)rpm</th> <th>500</th><th>1000</th><th>1500</th><th>2000</th><th>2500</th><th>3000</th><th>3500</th><th>4000</th><th>4500</th><th>5000</th><th>5500</th><th>6000</th><th>6500</th><th>7000</th><th>7500</th><th>8000</th><th>8500</th><th>9000</th><th>9500</th><th>10000</th> </tr> </thead> <tbody> <tr><td>0.0</td><td>25.000</td><td>25.000</td><td>25.000</td><td>25.000</td><td>25.000</td><td>25.000</td><td>25.000</td><td>25.000</td><td>25.000</td><td>25.000</td><td>25.000</td><td>25.000</td><td>25.000</td><td>25.000</td><td>25.000</td><td>25.000</td><td>25.000</td><td>25.000</td><td>25.000</td><td>25.000</td></tr> <tr><td>2.5</td><td>25.000</td><td>25.000</td><td>25.000</td><td>25.000</td><td>25.000</td><td>25.000</td><td>25.000</td><td>25.000</td><td>25.000</td><td>25.000</td><td>25.000</td><td>25.000</td><td>25.000</td><td>25.000</td><td>25.000</td><td>25.000</td><td>25.000</td><td>25.000</td><td>25.000</td><td>25.000</td></tr> <tr><td>5.0</td><td>25.000</td><td>25.000</td><td>25.000</td><td>25.000</td><td>25.000</td><td>25.000</td><td>25.000</td><td>25.000</td><td>25.000</td><td>25.000</td><td>25.000</td><td>25.000</td><td>25.000</td><td>25.000</td><td>25.000</td><td>25.000</td><td>25.000</td><td>25.000</td><td>25.000</td><td>25.000</td></tr> <tr><td>10.0</td><td>25.000</td><td>25.000</td><td>25.000</td><td>25.000</td><td>25.000</td><td>25.000</td><td>25.000</td><td>25.000</td><td>25.000</td><td>25.000</td><td>25.000</td><td>25.000</td><td>25.000</td><td>25.000</td><td>25.000</td><td>25.000</td><td>25.000</td><td>25.000</td><td>25.000</td><td>25.000</td></tr> <tr><td>25.0</td><td>25.000</td><td>25.000</td><td>25.000</td><td>25.000</td><td>25.000</td><td>25.000</td><td>25.000</td><td>25.000</td><td>25.000</td><td>25.000</td><td>25.000</td><td>25.000</td><td>25.000</td><td>25.000</td><td>25.000</td><td>25.000</td><td>25.000</td><td>25.000</td><td>25.000</td><td>25.000</td></tr> <tr><td>33.0</td><td>25.000</td><td>25.000</td><td>25.000</td><td>25.000</td><td>25.000</td><td>25.000</td><td>25.000</td><td>25.000</td><td>25.000</td><td>25.000</td><td>25.000</td><td>25.000</td><td>25.000</td><td>25.000</td><td>25.000</td><td>25.000</td><td>25.000</td><td>25.000</td><td>25.000</td><td>25.000</td></tr> <tr><td>50.0</td><td>25.000</td><td>25.000</td><td>25.000</td><td>25.000</td><td>25.000</td><td>25.000</td><td>25.000</td><td>25.000</td><td>25.000</td><td>25.000</td><td>25.000</td><td>25.000</td><td>25.000</td><td>25.000</td><td>25.000</td><td>25.000</td><td>25.000</td><td>25.000</td><td>25.000</td><td>25.000</td></tr> <tr><td>66.0</td><td>25.000</td><td>25.000</td><td>25.000</td><td>25.000</td><td>25.000</td><td>25.000</td><td>25.000</td><td>25.000</td><td>25.000</td><td>25.000</td><td>25.000</td><td>25.000</td><td>25.000</td><td>25.000</td><td>25.000</td><td>25.000</td><td>25.000</td><td>25.000</td><td>25.000</td><td>25.000</td></tr> <tr><td>75.0</td><td>25.000</td><td>25.000</td><td>25.000</td><td>25.000</td><td>25.000</td><td>25.000</td><td>25.000</td><td>25.000</td><td>25.000</td><td>25.000</td><td>25.000</td><td>25.000</td><td>25.000</td><td>25.000</td><td>25.000</td><td>25.000</td><td>25.000</td><td>25.000</td><td>25.000</td><td>25.000</td></tr> <tr><td>100.0</td><td>25.000</td><td>25.000</td><td>25.000</td><td>25.000</td><td>25.000</td><td>25.000</td><td>25.000</td><td>25.000</td><td>25.000</td><td>25.000</td><td>25.000</td><td>25.000</td><td>25.000</td><td>25.000</td><td>25.000</td><td>25.000</td><td>25.000</td><td>25.000</td><td>25.000</td><td>25.000</td></tr> </tbody> </table> </div> </div>				Map 1 - Quickshift.Quickshift cut time table (ms)																				Tps (%)rpm	500	1000	1500	2000	2500	3000	3500	4000	4500	5000	5500	6000	6500	7000	7500	8000	8500	9000	9500	10000	0.0	25.000	25.000	25.000	25.000	25.000	25.000	25.000	25.000	25.000	25.000	25.000	25.000	25.000	25.000	25.000	25.000	25.000	25.000	25.000	25.000	2.5	25.000	25.000	25.000	25.000	25.000	25.000	25.000	25.000	25.000	25.000	25.000	25.000	25.000	25.000	25.000	25.000	25.000	25.000	25.000	25.000	5.0	25.000	25.000	25.000	25.000	25.000	25.000	25.000	25.000	25.000	25.000	25.000	25.000	25.000	25.000	25.000	25.000	25.000	25.000	25.000	25.000	10.0	25.000	25.000	25.000	25.000	25.000	25.000	25.000	25.000	25.000	25.000	25.000	25.000	25.000	25.000	25.000	25.000	25.000	25.000	25.000	25.000	25.0	25.000	25.000	25.000	25.000	25.000	25.000	25.000	25.000	25.000	25.000	25.000	25.000	25.000	25.000	25.000	25.000	25.000	25.000	25.000	25.000	33.0	25.000	25.000	25.000	25.000	25.000	25.000	25.000	25.000	25.000	25.000	25.000	25.000	25.000	25.000	25.000	25.000	25.000	25.000	25.000	25.000	50.0	25.000	25.000	25.000	25.000	25.000	25.000	25.000	25.000	25.000	25.000	25.000	25.000	25.000	25.000	25.000	25.000	25.000	25.000	25.000	25.000	66.0	25.000	25.000	25.000	25.000	25.000	25.000	25.000	25.000	25.000	25.000	25.000	25.000	25.000	25.000	25.000	25.000	25.000	25.000	25.000	25.000	75.0	25.000	25.000	25.000	25.000	25.000	25.000	25.000	25.000	25.000	25.000	25.000	25.000	25.000	25.000	25.000	25.000	25.000	25.000	25.000	25.000	100.0	25.000	25.000	25.000	25.000	25.000	25.000	25.000	25.000	25.000	25.000	25.000	25.000	25.000	25.000	25.000	25.000	25.000	25.000	25.000	25.000
Map 1 - Quickshift.Quickshift cut time table (ms)																																																																																																																																																																																																																																																														
Tps (%)rpm	500	1000	1500	2000	2500	3000	3500	4000	4500	5000	5500	6000	6500	7000	7500	8000	8500	9000	9500	10000																																																																																																																																																																																																																																										
0.0	25.000	25.000	25.000	25.000	25.000	25.000	25.000	25.000	25.000	25.000	25.000	25.000	25.000	25.000	25.000	25.000	25.000	25.000	25.000	25.000																																																																																																																																																																																																																																										
2.5	25.000	25.000	25.000	25.000	25.000	25.000	25.000	25.000	25.000	25.000	25.000	25.000	25.000	25.000	25.000	25.000	25.000	25.000	25.000	25.000																																																																																																																																																																																																																																										
5.0	25.000	25.000	25.000	25.000	25.000	25.000	25.000	25.000	25.000	25.000	25.000	25.000	25.000	25.000	25.000	25.000	25.000	25.000	25.000	25.000																																																																																																																																																																																																																																										
10.0	25.000	25.000	25.000	25.000	25.000	25.000	25.000	25.000	25.000	25.000	25.000	25.000	25.000	25.000	25.000	25.000	25.000	25.000	25.000	25.000																																																																																																																																																																																																																																										
25.0	25.000	25.000	25.000	25.000	25.000	25.000	25.000	25.000	25.000	25.000	25.000	25.000	25.000	25.000	25.000	25.000	25.000	25.000	25.000	25.000																																																																																																																																																																																																																																										
33.0	25.000	25.000	25.000	25.000	25.000	25.000	25.000	25.000	25.000	25.000	25.000	25.000	25.000	25.000	25.000	25.000	25.000	25.000	25.000	25.000																																																																																																																																																																																																																																										
50.0	25.000	25.000	25.000	25.000	25.000	25.000	25.000	25.000	25.000	25.000	25.000	25.000	25.000	25.000	25.000	25.000	25.000	25.000	25.000	25.000																																																																																																																																																																																																																																										
66.0	25.000	25.000	25.000	25.000	25.000	25.000	25.000	25.000	25.000	25.000	25.000	25.000	25.000	25.000	25.000	25.000	25.000	25.000	25.000	25.000																																																																																																																																																																																																																																										
75.0	25.000	25.000	25.000	25.000	25.000	25.000	25.000	25.000	25.000	25.000	25.000	25.000	25.000	25.000	25.000	25.000	25.000	25.000	25.000	25.000																																																																																																																																																																																																																																										
100.0	25.000	25.000	25.000	25.000	25.000	25.000	25.000	25.000	25.000	25.000	25.000	25.000	25.000	25.000	25.000	25.000	25.000	25.000	25.000	25.000																																																																																																																																																																																																																																										

If the Quick shift strategy is enabled (Configuration -> Parameters -> Strategies -> Quick shift) and the corresponding conditions are met, this table is applied.

X Axis = RPM

Y Axis = TPS

Entry points = cut times in ms, used during gear shifts.

8.13 Traction control

Table		2D	3D																																																																																																			
<div style="display: flex;"> <div style="flex: 1;"> <ul style="list-style-type: none"> GasGas - MC 250F 2021 <ul style="list-style-type: none"> Configuration <ul style="list-style-type: none"> Parameters CAN configuration Sensors Map 1 (Default map 1)* <ul style="list-style-type: none"> Fuel Ignition Launch control Quickshift Traction control <ul style="list-style-type: none"> Traction control Map 2 (Default map 2) Map 3 (Default map 3) Map 4 (Default map 4) Map 5 (Default map 5) Map 6 (Default map 6) Expansions </div> <div style="flex: 2;"> <table border="1"> <thead> <tr> <th colspan="16">Map 1 - Traction control.Traction control</th> </tr> <tr> <th>Tps (%)</th> <th>0.0</th><th>2.5</th><th>5.0</th><th>8.0</th><th>10.0</th><th>12.0</th><th>15.0</th><th>20.0</th><th>25.0</th><th>30.0</th><th>40.0</th><th>50.0</th><th>60.0</th><th>70.0</th><th>80.0</th><th>90.0</th> </tr> </thead> <tbody> <tr> <td>rpm/s</td> <td>0</td><td>0</td><td>0</td><td>0</td><td>0</td><td>0</td><td>0</td><td>0</td><td>0</td><td>0</td><td>0</td><td>0</td><td>0</td><td>0</td><td>0</td><td>0</td> </tr> <tr> <td>Ignition advance offset (°)</td> <td>0.0</td><td>0.0</td><td>0.0</td><td>0.0</td><td>0.0</td><td>0.0</td><td>0.0</td><td>0.0</td><td>0.0</td><td>0.0</td><td>0.0</td><td>0.0</td><td>0.0</td><td>0.0</td><td>0.0</td><td>0.0</td> </tr> <tr> <td>Injection phase offset advance (°)</td> <td>0.0</td><td>0.0</td><td>0.0</td><td>0.0</td><td>0.0</td><td>0.0</td><td>0.0</td><td>0.0</td><td>0.0</td><td>0.0</td><td>0.0</td><td>0.0</td><td>0.0</td><td>0.0</td><td>0.0</td><td>0.0</td> </tr> <tr> <td>Correction maintenance (r)</td> <td>0</td><td>0</td><td>0</td><td>0</td><td>0</td><td>0</td><td>0</td><td>0</td><td>0</td><td>0</td><td>0</td><td>0</td><td>0</td><td>0</td><td>0</td><td>0</td> </tr> </tbody> </table> </div> </div>		Map 1 - Traction control.Traction control																Tps (%)	0.0	2.5	5.0	8.0	10.0	12.0	15.0	20.0	25.0	30.0	40.0	50.0	60.0	70.0	80.0	90.0	rpm/s	0	0	0	0	0	0	0	0	0	0	0	0	0	0	0	0	Ignition advance offset (°)	0.0	0.0	0.0	0.0	0.0	0.0	0.0	0.0	0.0	0.0	0.0	0.0	0.0	0.0	0.0	0.0	Injection phase offset advance (°)	0.0	0.0	0.0	0.0	0.0	0.0	0.0	0.0	0.0	0.0	0.0	0.0	0.0	0.0	0.0	0.0	Correction maintenance (r)	0	0	0	0	0	0	0	0	0	0	0	0	0	0	0	0
Map 1 - Traction control.Traction control																																																																																																						
Tps (%)	0.0	2.5	5.0	8.0	10.0	12.0	15.0	20.0	25.0	30.0	40.0	50.0	60.0	70.0	80.0	90.0																																																																																						
rpm/s	0	0	0	0	0	0	0	0	0	0	0	0	0	0	0	0																																																																																						
Ignition advance offset (°)	0.0	0.0	0.0	0.0	0.0	0.0	0.0	0.0	0.0	0.0	0.0	0.0	0.0	0.0	0.0	0.0																																																																																						
Injection phase offset advance (°)	0.0	0.0	0.0	0.0	0.0	0.0	0.0	0.0	0.0	0.0	0.0	0.0	0.0	0.0	0.0	0.0																																																																																						
Correction maintenance (r)	0	0	0	0	0	0	0	0	0	0	0	0	0	0	0	0																																																																																						

Traction control is a system that stops the wheels of a vehicle from spinning when excess power is applied.

If the traction control strategy is enabled (Map -> Traction control -> Enable) and the corresponding conditions are met, this table is applied.

This is based on TPS (X axis) and four rows of entries:

- Engine acceleration (RPM/s),
- Ignition advance offset (Advance (°)),
- Injection phase offset (Advance (°))
- Correction maintenance (Rev).

8.14 – Expansions



This section is made to enable the Handlebar switch.

9 – Data view – special key and visualization

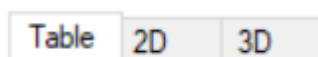

The data view area can show the mapping tables in three different ways:

- Table Format
- 2D Format
- 3D Format (will be available soon)

It is possible to switch this view by pushing the tab placed on top of the data view area or using the shortcut:

- Ctrl button plus 1, 2 or 3 (1 for table view, 2 for 2D view and 3 for the 3D view).

9.1 - Table Format

This mode allows to type in the entry values in the cells, modify them and the breakpoints. The entries can be modified one by one, or grouped together, selecting. The selection on the table can be done with **shift + arrow** keys or using a mouse.

To select a group of entries:

- Left click and press for desired table zone (mouse)
- Shift + Arrows move for desired zone (keyboard)

Once elements (entries) are selected, it is possible to change their value in the following ways:

Mouse

- Right click (mouse) a pop-up is prompted to type the desired change.
 - o Add -> algebraic addition of a defined quantity to the selected entry(s)
 - o Add% -> percentual addition of a defined quantity to the selected entry(s)
 - o Set -> forcing the desired value to the selected entry(s)

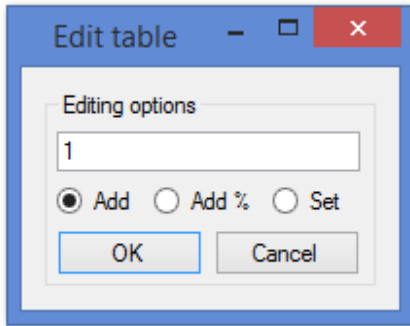

Keyboard

- Ctrl+Up -> Increment the selected entries for entry resolution x 10.
- Ctrl+Down -> Decrement the selected entries for entry resolution x 10.
- Alt+Up -> Increment the selected entries for entry resolution.
- Alt+Down -> Decrement the selected entries for entry resolution.
- Type in the value -> Force all entries to the desired number.

Once data have been changed, modified cells are highlighted in orange to show that the data is changed but not yet sent to the ECU. To send it to the ECU push enter on the keyboard, and the cells transmitted to the ECU are highlighted in green, to show that they have been written in temporary way. They have not been flashed into the ECU for permanent use.

To write the whole table directly into the ECU it is possible to select it clicking on the top left section. Then (with ECU connected and project opened) clicking the right button of the mouse on the map selected (left menu) you can directly write the whole table into the ECU.

Shortcuts for these tasks are available:

- Alt-Shift-T, to write the whole table.
- Alt-T, to read the whole table.

9.2 - 2D Format

To select the 2D graphs is possible:

Direct mouse selection (mouse)

- Once the mouse focus is on this window (click) move among graphs with the arrow keys (keyboard)

Graphs can be modified point-by-point, after having selected the desired point:

Mouse

- Holding pressed the right button and dragging the line.

Keyboard

- Ctrl+Up -> Increment the selected entries for entry resolution (+ 0,1 per pressure)
- Ctrl+Down -> Decrement the selected entries for entry resolution (+ 0,1 per pressure)
- Alt+Up -> Increment the selected entries for entry resolution.
- Alt+Down -> Decrement the selected entries for entry resolution.

Once data have been changed in the 2D graph, to write them into the ECU return in the Table view and press the Enter Key.

In the Table view, breakpoints can be locked not to change them unintentionally. This is done ticking the flag at the right bottom corner of the Data view area.

Lock breakpoints

To focus on a particular line, you can click on the line and press the shortcut Ctrl-Q. This hides the other lines. Use Ctrl-W to make them reappear.

9.3 - 3D Format

This feature will be uploaded soon. A proper function explanation will be prepared at that time.

10 – Live Measures view box

INJ1 time	<input type="text" value="--"/>	ECT	<input type="text" value="--"/>	IGN	<input type="text" value="--"/>	Sync err	<input type="text" value="--"/>
INJ1 phase	<input type="text" value="--"/>	IAT	<input type="text" value="--"/>	INJ base	<input type="text" value="--"/>	Eng pos	<input type="text" value="--"/>
INJ2 time	<input type="text" value="--"/>	V ign	<input type="text" value="--"/>	RPM	<input type="text" value="--"/>	Eng state	<input type="text" value="--"/>
INJ2 phase	<input type="text" value="--"/>	λ	<input type="text" value="--"/>	TPS	<input type="text" value="--"/>	Eng revs	<input type="text" value="--"/>

This area is used to monitor live data. Available parameters change according to the licence in use. This is activated only when the ECU is connected. Can be hidden/shown pressing the hide/show Live Measures panel button in the icon bar. Hiding this panel is recommended when the Data view area must be maximized. Only if Live Measures is activated, live faults can be shown by the diagnostics section.

Live Measures parameters:

INJ1 time: Total injector1 time of injection

INJ1 phase: Injector 1 phase of injection

INJ2 time: Total injector2 time of injection

INJ2 phase: Injector 2 phase of injection

ECT: Engine coolant temperature

IAT: Intake air temperature

V ign: Motorcycle ignition voltage

λ: Lambda values (if ECU connected to an AiM logger that has LCU1 controller)

IGN: Ignition advance

INJ base: Injection base time from main table

RPM: RPM at the moment

TPS: Throttle position percentage at the moment

Sync err: Synchronism errors

Eng pos: Engine position, divided in Seek, Semi phased and Phased

Eng state: Engine state divided in stop, cranking and running.

Eng revs: Engine revolutions number

11 – Info bar

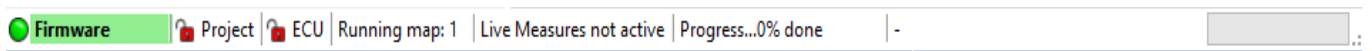

The bottom Info bar is a quick monitor for the ECU and software communication state. There are the following fields.

- Semaphore
 - red light: the ECU is not recognized.
 - orange blinking light: ECU is being recognized.
 - green: the ECU is recognized.

- Ecu status (not connected or firmware, it depends on whether the control unit is connected. If the ecu is not connected you cannot write or flash anything in the ECU).
- Project (project locked by password or not).
- ECU (ECU target locked by password or not).
- Running map number
- Live Measures status (active – not active).
- Operation progress percentage
- Status bar showing the operation progress of a process (opposite corner in the bottom Info bar)

Appendix A – Taipan ECU Part Numbers

XE1UCBT00	UC BRIDGE TUNER
XE1UCB000	UC BRIDGE
XE1HBS000	HBS
XE1ECUCB0	ECU TAIPAN
XE1ECUHBSUCB0	ECU + HBS + UC BRIDGE
XE1ECUHBS00	ECU + HBS

Appendix B – ECU Taipan dimensions and pinout

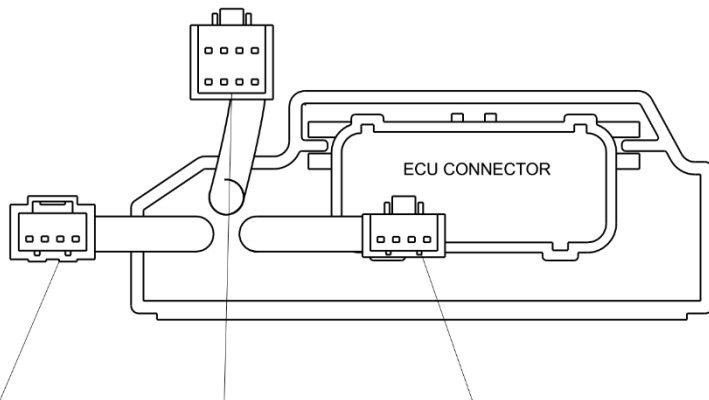
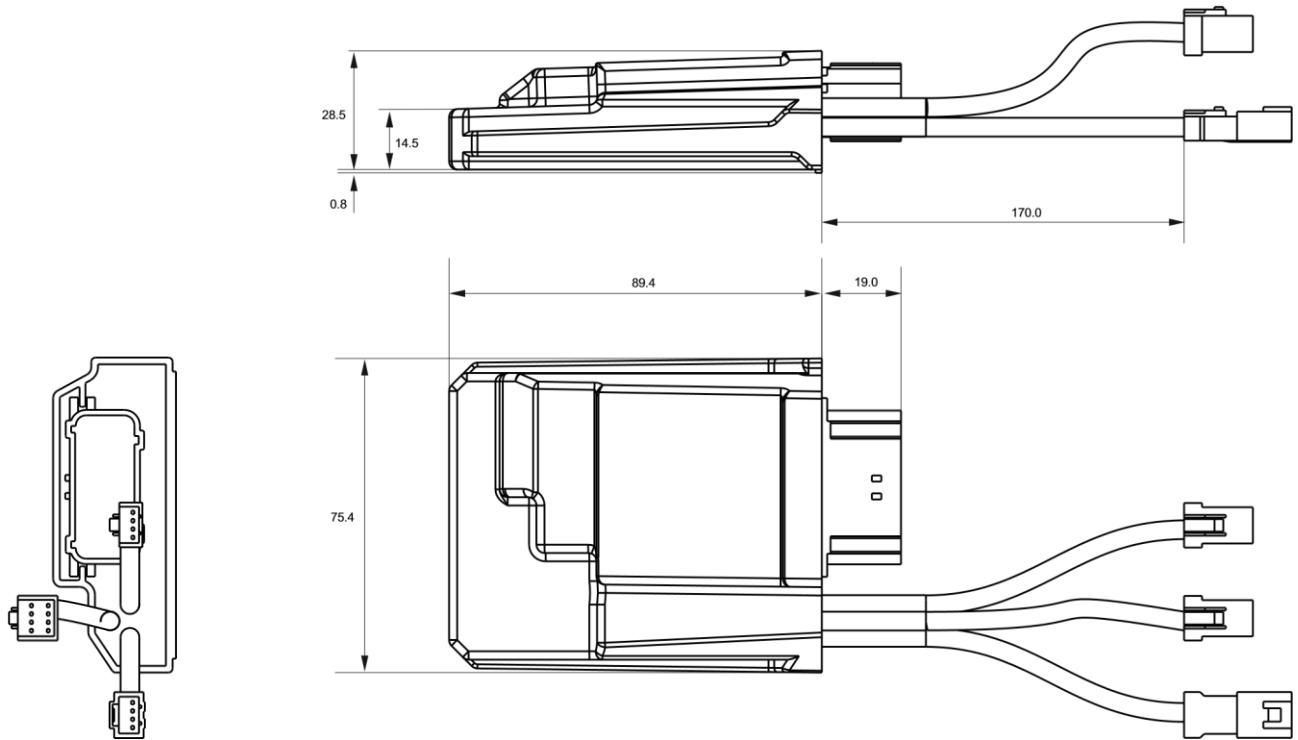

JST 04T-JWPF-VSLE-S CONNECTOR EXT VIEW	JST 08R-JWPF-VSLE-D CONNECTOR EXT VIEW	JST 04R-JWPF-VSLE-S CONNECTOR EXT VIEW
1 - GND 2 - CAN CAL HIGH 3 - CAN CAL LOW 4 - 12V IN	1 - 12V SECOND INJ 2 - LOW SIDE SECOND INJ 3 - LOW SIDE 4 - GND 5 - ANALOG INPUT 1 6 - ANALOG INPUT 2 7 - DNC 8 - DNC	1 - GND 2 - CAN EXP HIGH 3 - CAN EXP LOW 4 - 12V OUT (switched)

Appendix D – Main terms

Here, a list of terms used in this document and relevant to the Spark software.

Configuration: A Configuration includes the base parameters not directly related to the engine performance. i.e.:

- Set up the second injector if present.
- Set up range of sensor plausibility.
- Set up parameters for the map switch like fuel correction, threshold of RPM to activate the correction chosen.
- Enable/disable launch control.
- Enable/disable pre injection.
- Set up the RPM limiters.
- Set up strategies (The drop sensor, injection, injector phase strategy, neutral strategy, quick shift).
- Set up the VB out (Voltage Battery Output).
- Set up the Can configuration.
- Set up sensors.

Table: The main feature of a table is the presences of one or two breakpoint axis dependent from the type of table (2D: One breakpoint axis, 3D: two breakpoint axis). The table is composed by cells that are a correlation between variables. Here below an example of table.

Map 1 - Fuel.Injection main #1 (ms)

Tps (%/rpm)	250	500	750	1000	1250	1500	1750	2000	2250	2500	2750	3000	3250	3500	3750	4000	4250	4500	4750	5000	5250	5500	5750	6000	6250	6500	6750	7000	7250	7500	7750	8000	8250	8500	8750	9000
0.0	0.760	0.760	0.760	0.760	0.760	0.760	0.760	0.760	0.760	0.760	0.760	0.760	0.760	0.760	0.770	0.740	0.640	0.610	0.560	0.500	0.450	0.420	0.380	0.333	0.314	0.285	0.285	0.285	0.285	0.285	0.285	0.285	0.285	0.285	0.285	0.271
2.5	1.180	1.180	1.180	1.180	1.180	1.180	1.062	1.053	1.044	1.071	1.062	1.053	0.999	0.963	0.945	0.909	0.872	0.828	0.761	0.709	0.655	0.619	0.573	0.546	0.513	0.496	0.453	0.445	0.419	0.403	0.385	0.368	0.343	0.350	0.340	
5.0	1.380	1.380	1.380	1.380	1.380	1.380	1.242	1.233	1.233	1.242	1.242	1.224	1.197	1.179	1.159	1.113	1.069	1.014	0.978	0.922	0.877	0.832	0.795	0.778	0.752	0.718	0.674	0.648	0.638	0.614	0.599	0.571	0.555	0.550	0.550	
10.0	1.840	1.840	1.840	1.840	1.840	1.840	1.840	1.840	1.860	1.940	1.970	1.930	1.850	1.720	1.640	1.550	1.490	1.440	1.410	1.380	1.360	1.330	1.290	1.250	1.231	1.202	1.173	1.144	1.116	1.080	1.063	1.036	1.018	1.014	1.000	0.990
25.0	3.020	3.020	3.020	3.020	3.020	3.020	3.010	2.990	3.020	3.210	3.350	3.360	3.180	2.960	2.810	2.700	2.630	2.580	2.530	2.490	2.450	2.380	2.350	2.296	2.247	2.228	2.218	2.209	2.200	2.162	2.143	2.124	2.106	2.087	2.080	2.060
33.0	3.510	3.510	3.510	3.510	3.510	3.510	3.480	3.440	3.470	3.560	3.570	3.610	3.490	3.120	3.030	2.990	2.950	2.910	2.900	2.890	2.890	2.880	2.900	2.910	2.920	2.920	2.910	2.900	2.880	2.840	2.760	2.679	2.632	2.594	2.537	2.480
50.0	3.660	3.660	3.660	3.660	3.660	3.660	3.620	3.580	3.620	3.760	3.790	3.840	3.610	3.260	3.090	3.060	3.050	3.030	3.070	3.120	3.220	3.330	3.450	3.580	3.680	3.780	3.830	3.880	3.890	3.900	3.880	3.850	3.800	3.740	3.640	3.540
66.0	3.750	3.750	3.750	3.750	3.750	3.750	3.710	3.670	3.720	3.880	4.000	3.970	3.670	3.350	3.150	3.100	3.100	3.110	3.130	3.150	3.270	3.390	3.530	3.670	3.810	3.960	4.060	4.000	4.220	4.280	4.320	4.340	4.330	4.320	4.250	4.190
75.0	3.650	3.650	3.650	3.650	3.570	3.460	3.420	3.380	3.430	3.570	3.640	3.610	3.340	3.180	3.010	2.930	2.930	2.930	2.980	3.020	3.150	3.270	3.400	3.530	3.620	3.770	3.880	4.000	4.050	4.170	4.220	4.270	4.270	4.270	4.250	4.240
100.0	3.570	3.570	3.570	3.570	3.380	3.260	3.230	3.150	3.230	3.380	3.410	3.390	3.210	3.010	2.860	2.720	2.700	2.680	2.680	2.700	2.860	3.030	3.030	3.180	3.260	3.400	3.540	3.680	3.780	3.890	4.060	4.150	4.200	4.250	4.260	4.280

Map: A Map is the combination of all the parameters governed by the ECU directly related to engine performance and consist of different tables. The main maps are the fuel and ignition, but you can also set up the tables of various strategies and sensors, as we see in the next chapters.

Project: A project is the union of ECU configuration and ECU Maps.

Breakpoint: A breakpoint is the segmentation of the axis. Breakpoints can be equally distributed or increased in specific areas where more accuracy is desired. The trend of breakpoints is monotone.

Entry: An entry is the desired value that the user wants to set in a specific cell in the table.

Engine hour meter: The engine hour meter is the time the engine has been used with this ECU.

Write: means that the data is sent real time to the ECU, but it is not stored in the ECU. As soon as this is turned off, data “written” are cleared. Generally used to tune some entries live.

Flash: means that the data is sent real time to the ECU and it is stored in a permanent memory. Generally used to write a complete map.

TPS: Throttle Position Sensor in %.

ECT: Engine Coolant Temperature.

MAP: Manifold Air Pressure.

Baro: Barometric Air Pressure.

EWT: Engine Water Temperature.

IAT: Intake Air Temperature.

VIGN: Ignition Voltage in V.

Project File: It is the combination of configuration and all the maps.

Valid Map: A map may be not valid in these situations:

- if it is not completely transmitted to the ECU.
- it is not compatible with the firmware version of the ECU.

Running Map: A Running Map is the map actually used by the ECU.

Appendix E – Pre-injection

Pre-injection is intended to avoid starting problems, which could happen in some situations:

- When the water or coolant temperature is low.
- When the geometry of the ducts is not very straight in the direction of the intake valve.
- When the position of the injector is not in line with the intake valve.

The basic purpose of this strategy is to activate, at the beginning of the crank phase, a disposable injection, which goes to wet the intake duct. This allows the subsequent injections not to settle on the ducts, to facilitate starting the motorcycle.

Looking at the image here down:

- Light blue: flywheel signal
- Green: injector command (injects when piloted low)

As can be seen, this strategy, if enabled, intervenes when the ECU is powered at the first rotation of the flywheel to the first tooth detected, regardless of the position of the piston.

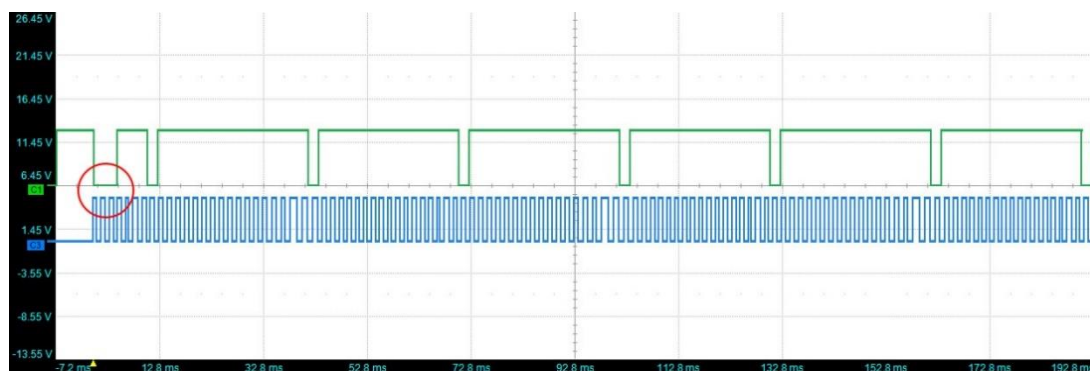

In the red circle, the pre-injection time is highlighted.

This strategy is enabled within the configuration of the project file, in: Configurations->Parameters->Pre-Injection

Pre-injection:



For every map, a pre-injection table is available:

Ms\°C	-15	-3	0	9	14	20	24	34	39	66	82	99
	22	13	9	7	5	4	4	4	3	2	2	2

where the X-axis shows the water temperature, and the entry points are the pre-injection times in msec. The table above, to be considered as an example, was obtained on an experimental basis, verifying, at the different temperatures at the start-up, how the pre-injection affects the start-up itself. It is easy to see how the pre-injection is more important at low temperatures.

Appendix F – Injection crank correction (%)

The crank injection correction intervenes to facilitate engine starting, when an extra amount of fuel is required than is necessary to keep the engine running in normal conditions. To define this correction, the following table is available:

Map 1 - Fuel Injection crank correction (%) – -40.0°C @0r

°Cv	0	1	2	3	4	5	6	7	8	9	10	11	12	13	14	15	16	18	120	300
-40.0	152.0	155.0	158.0	159.0	159.0	158.5	157.8	154.9	150.8	145.7	140.9	137.7	137.7	137.5	137.5	137.5	137.5	141.5	145.5	145.5
-30.0	142.0	145.0	148.0	149.0	149.0	148.5	147.8	144.9	140.8	135.7	130.9	127.7	127.7	127.5	127.5	127.5	127.5	131.5	135.5	135.5
-20.0	132.0	135.0	138.0	139.0	139.0	138.5	137.8	134.9	130.8	125.7	120.9	117.7	117.7	117.5	117.5	117.5	117.5	121.5	125.5	125.5
-10.0	122.0	125.0	128.0	129.0	129.0	128.5	127.8	124.9	120.8	115.7	110.9	107.7	107.7	107.5	107.5	107.5	107.5	111.5	115.5	115.5
0.0	109.0	113.0	117.0	119.0	120.0	119.5	117.8	114.9	109.8	103.7	95.9	89.7	88.7	88.5	88.5	88.5	89.5	96.5	102.5	102.5
10.0	97.0	101.0	105.0	108.0	110.0	109.5	108.8	104.9	99.8	91.7	84.9	78.7	75.7	74.5	74.5	74.5	76.5	82.5	88.5	88.5
20.0	82.0	87.0	92.0	95.0	97.0	97.5	95.8	92.9	86.8	78.7	69.9	64.7	63.7	63.5	63.5	63.5	64.5	67.5	69.5	69.5
30.0	53.0	59.0	63.0	66.0	67.0	66.5	63.8	59.9	55.8	50.7	45.9	40.7	35.7	33.5	32.5	32.5	32.5	33.5	38.5	45.0
40.0	26.0	28.0	30.0	31.0	31.0	33.0	38.0	42.0	45.0	46.0	43.0	38.0	25.0	15.0	15.0	15.0	15.0	17.0	23.0	30.0
50.0	22.0	24.0	27.0	27.0	26.0	27.0	33.0	39.0	43.0	44.0	43.0	38.0	25.0	15.0	15.0	15.0	15.0	15.0	15.0	30.0
55.0	22.0	24.0	27.0	27.0	26.0	27.0	33.0	39.0	43.0	44.0	43.0	38.0	25.0	15.0	15.0	15.0	15.0	15.0	15.0	0.0
60.0	20.0	21.0	23.0	24.0	22.0	22.0	28.0	34.0	38.0	39.0	38.0	33.0	25.0	15.0	15.0	15.0	15.0	15.0	15.0	0.0
65.0	20.0	21.0	23.0	24.0	22.0	22.0	28.0	34.0	38.0	39.0	38.0	33.0	25.0	15.0	15.0	15.0	15.0	15.0	15.0	0.0
70.0	10.0	9.0	12.5	10.5	10.5	11.0	14.0	17.0	19.0	19.5	19.0	16.5	12.5	7.5	7.5	7.5	7.5	7.5	7.5	0.0
75.0	0.0	0.0	0.0	0.0	0.0	0.0	0.0	0.0	0.0	0.0	0.0	0.0	0.0	0.0	0.0	0.0	0.0	0.0	0.0	0.0
80.0	0.0	0.0	0.0	0.0	0.0	0.0	0.0	0.0	0.0	0.0	0.0	0.0	0.0	0.0	0.0	0.0	0.0	0.0	0.0	0.0
85.0	0.0	0.0	0.0	0.0	0.0	0.0	0.0	0.0	0.0	0.0	0.0	0.0	0.0	0.0	0.0	0.0	0.0	0.0	0.0	0.0
90.0	0.0	0.0	0.0	0.0	0.0	0.0	0.0	0.0	0.0	0.0	0.0	0.0	0.0	0.0	0.0	0.0	0.0	0.0	0.0	0.0
95.0	0.0	0.0	0.0	0.0	0.0	0.0	0.0	0.0	0.0	0.0	0.0	0.0	0.0	0.0	0.0	0.0	0.0	0.0	0.0	0.0
150.0	0.0	0.0	0.0	0.0	0.0	0.0	0.0	0.0	0.0	0.0	0.0	0.0	0.0	0.0	0.0	0.0	0.0	0.0	0.0	0.0

This table is defined by:

- X axis: number of motor revolutions
- Y axis: engine coolant temperature
- Entry Points: injection time correction percentage

As stated, this strategy works for a limited number of revolutions, as defined in the last value of the X-Axis.

So, once the Start Button is pushed, the injection time will be calculated considering all the following tables:

- the main table "Main table" indicating the injection time,
- the injector battery compensation,
- compensation of the air temperature
- compensation of the barometric pressure
- **the contribution deriving from the crank injection time correction table.**

Let us imagine scrolling this table from left to right at start-up: once the revolutions indicated as the last point on the X axis are finished, the crank phase can be considered finished, and the crank injection correction is interrupted. At this point, the Injection Time Compensation Table will intervene based on the temperature of the coolant.

So, in the example of the table above, once the 300 revolutions of the engine have been exceeded, the following contributions will intervene:

- the “main” table indicating the injection time
- the injector battery compensation
- compensation of the air temperature
- compensation of the barometric pressure
- **the contribution deriving from the interpolation of the injection time compensation table as a function of the temperature of the coolant.**

The graph below shows an example of strategy intervention and management:

pink: water temperature

green: number of motor revolutions

blue: correction contribution to the crank

red: water temperature correction contribution

white: lambda probe value

orange: RPM

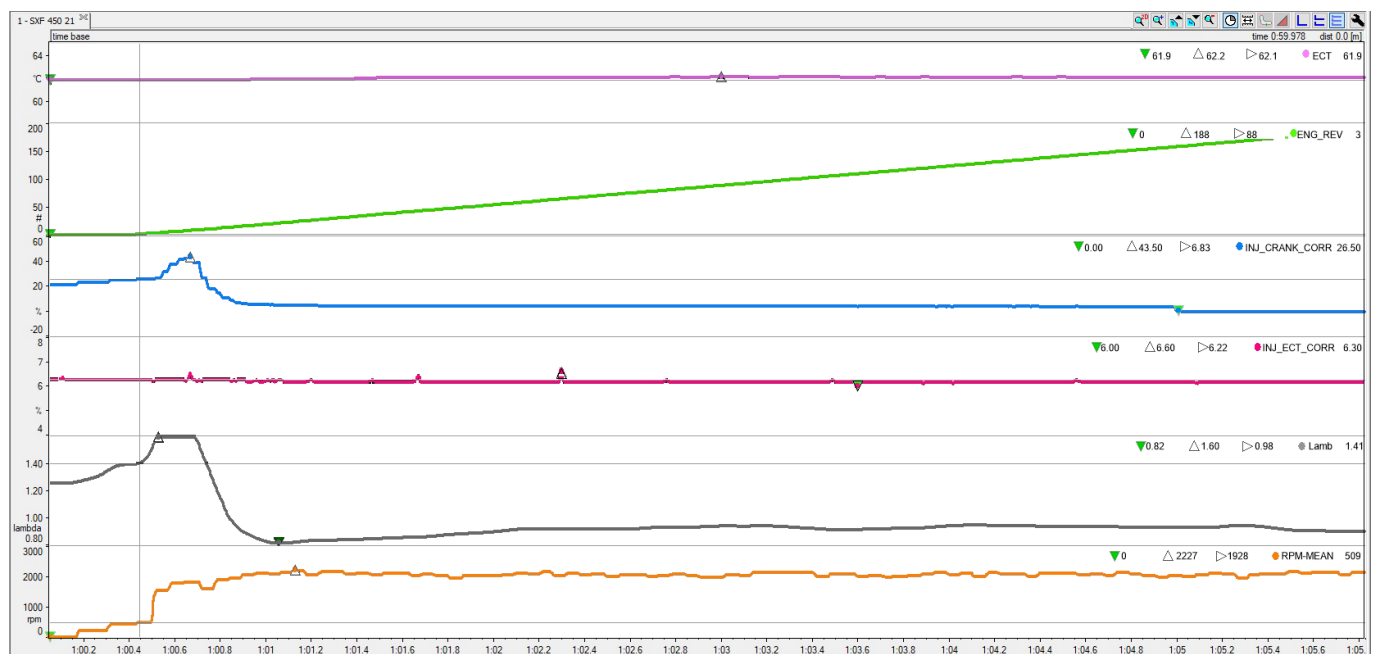

In this example, in the very first revolutions managed by the starter, there is a correction contribution to the crank of 20%. The lambda value will show the effect of the crank - correction a few revolutions after the implementation as shown below.

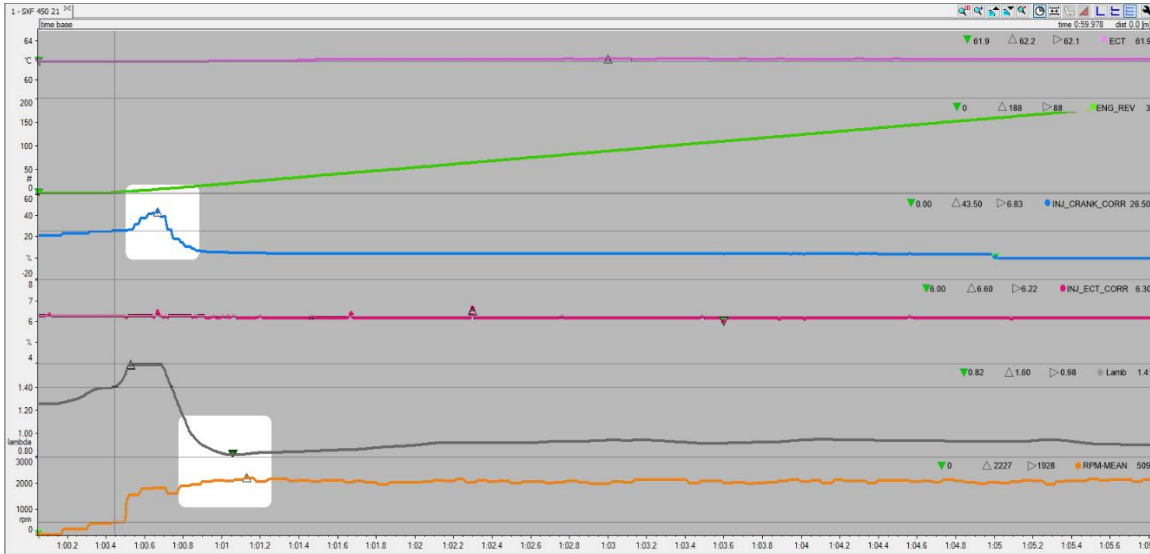

In the picture here above, you may note the crank injection correction peak and the effect of this correction on the lambda level.

The lambda value at this stage is very important:

- if too low "the engine drowns" (too much gasoline) and it will not start, with the risk of wetting the spark plug
- if it is too high, the gasoline will not be enough to start the engine.

After the crank, the engine is at idle, and the lambda value will stabilize at the desired target value, as shown in the image below.

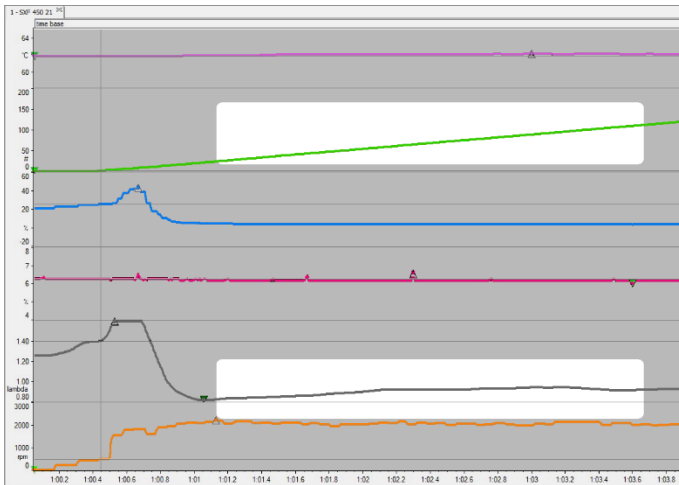

The last image shows exactly when the correction of the injection to the crank stops, and the correction is managed in accordance with the coolant temperature.

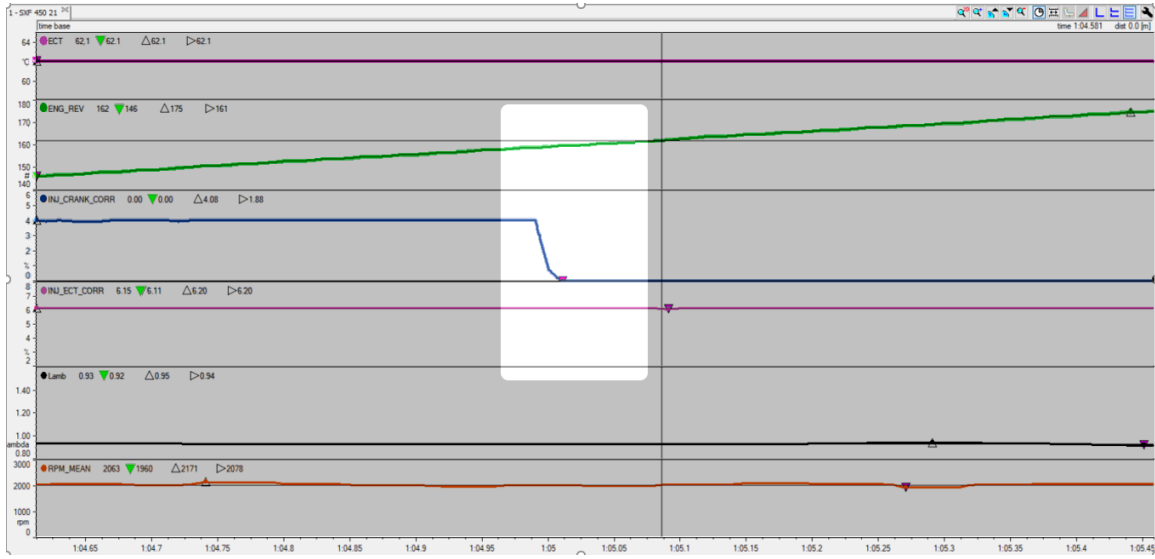

Appendix G – Injection N battery correction

One of the most important parameters for the engine control is the injection time, i.e., the duration of the injector command pulse so that the desired amount of petrol enters the combustion chamber of the engine. The injection time is calculated based on parameters, some of which depend on the characteristics of the injector, while others depend on other factors, such as water temperature, air, barometric pressure, etc. Here we see how the injector power supply voltage affects the opening time of the injector during the injection. The injector can be schematized as in this image:



This is a very simple circuit consisting of an inductor and a resistor. The inductive component, depending on the applied voltage, will make the injector open more or less quickly. Injector manufacturers always provide a table such as this one below, which represents the characterization of the injector itself. The table is very simple:

G2-99-0123

350 CC/MIN - 32 LBS/HR



EV6/EV14/USCAR electrical connector

Fuel Pressure		Voltage Offset					Flow Rate	
PSID	BAR	8 Volts	10 Volts	12 Volts	14 Volts	16 Volts	cc/min	lbs/hr
43.5	3.00	1.890	1.530	1.120	0.750	0.490	309	29
45	3.10	1.935	1.518	1.095	0.733	0.485	321	31
50	3.44	1.980	1.505	1.070	0.715	0.480	334	32
55	3.79	2.025	1.492	1.045	0.697	0.475	346	33
60	4.13	2.070	1.480	1.020	0.680	0.470	358	34
65	4.48	2.190	1.555	1.060	0.710	0.500	371	35
70	4.82	2.310	1.630	1.110	0.740	0.530	383	36
75	5.17	2.370	1.675	1.135	0.765	0.550	396	38
80	5.51	2.430	1.720	1.170	0.790	0.570	408	39
85	5.86	2.485	1.765	1.210	0.820	0.595	420	40
90	6.20	2.540	1.810	1.250	0.850	0.620	433	41
95	6.55	2.600	1.855	1.280	0.875	0.635	449	43
100	6.89	2.660	1.900	1.310	0.900	0.650	464	44



STANDARD

Voltage offset values are in milliseconds ms - 1ms = 1000us

At a certain fuel pressure (column 1/2) to obtain the desired amount of fuel (column 8/9), the injector must remain open for the time in msec depending on the power supply voltage indicated in the various "Voltage Offset" columns (columns 3/7).

The overall injection time driven by the ECU will therefore be given by considering, in addition to the set of contributions on the main table, also from this "offset" strictly dependent on the intrinsic characteristics of the injector.

Appendix H – Injection BAP correction

- BAP means Barometric Air Pressure, the weight exerted on the Earth by the air present in the atmosphere. The barometric pressure is therefore the pressure exerted at a certain point by the column of air that goes from the highest point of the atmosphere to the ground. It is obvious that the higher you move, the lower is the barometric pressure value.
- AFR means Air Fuel Ratio, that is the ratio between the intake air and the injected gasoline.

On a beautiful day at sea level the barometric pressure is 1020mBar, and a motorcycle at idle speed will have an AFR of 0.89. If you go up to 2500 m (8000 ft), where the air pressure is 780mBar, how will the lambda change? Given the premises described above, and knowing that as the height increases, the weight of the air column decreases, there is less air at altitude and therefore the AFR ratio decreases. If in these conditions we left the injected petrol unchanged, our engine would get greased, with even the risk of being shut down due to too much injected petrol.

Injection BAP correction serves to avoid this effect and acts by decreasing the percentage of petrol injected as the barometric pressure decreases in order to maintain the target lambda value.

This compensation table is very simple and is shown below:

%\mbar	400	450	500	550	600	650	700	750	800	850	900	950	1000	1050	1100	1200
	-50.0	-50.0	-50.0	-45.0	-40.0	-37.0	-32.0	-27.0	-22.0	-17.0	-10.0	-5.0	0.0	0.0	5.0	10.0

The pressure value in mBar is shown on the X axis, and the percentage correction on injected petrol as an entry point value.

Appendix I – Transient management

The management of transients in a dirt motorcycle is one of the most important calculations performed by the ECU and represents the heart of all its strategies.

The goodness and speed in implementation are the key points that allow you to have a constant and reactive behavior in the fast throttle opening and closing transients as well as substantially increasing the rider- motorcycle feeling.

Let us think about the use that a cross rider makes of the throttle grip during a session. The transient opening-closing represents 80-85% of the time on the track, while in the remaining 15-20% the TPS is in a stationary situation at 0%, i.e., in the points where the gas is released.

This premise may be useful to understand how, on the opposite to what happens in the tuning of track engines, in motocross the lambda sensor cannot be of any help in the closing-loop, even if it is very useful, as we will see, to verify the goodness of the strategy.

The transient corrections are present in every map, and are divided into:

- "Correction of the injection in transients" where the injected fuel is corrected by a percentage
- "Correction of ignition in transients" where the ignition advance is corrected by an offset.

Finally, we have to set the corrections, both for the injection transients and for the ignition transients, in opening and closing the throttle.

Below are some images from the Spark software describing what has been said.

Injection correction for opening throttle transients

Tps (%)	2.0	3.5	4.5	9.0	15.0	20.0	25.0	30.0	35.0	37.5	40.0	45.0	50.0	60.0	70.0	80.0
Opening speed (%/s)	190	300	320	360	360	360	650	650	650	650	650	650	650	650	650	650
Correction (%)	5.0	5.0	8.0	10.0	15.0	15.0	20.0	25.0	30.0	30.0	30.0	30.0	30.0	20.0	20.0	20.0
Correction time (r)	5	5	5	5	5	5	5	5	5	5	5	5	5	5	4	4

Injection correction for closing throttle transients

Tps (%)	15.0	25.0	30.0	32.0	35.0	38.0	43.0	50.0	54.0	57.0	60.0	65.0	70.0	75.0	80.0	85.0
Closing speed (%/s)	-820	-750	-700	-688	-664	-650	-450	-450	-450	-450	-410	-400	-400	-400	-400	-400
Correction (%)	-40.0	-40.0	-40.0	-45.0	-45.0	-45.0	-45.0	-45.0	-45.0	-45.0	-45.0	-45.0	-45.0	-45.0	-45.0	-45.0
Correction time (r)	6	6	6	6	5	5	5	5	5	4	4	4	4	3	3	3

Ignition correction for opening throttle transient

Tps (%)	2.0	3.5	4.5	9.0	15.0	20.0	25.0	30.0	35.0	37.5	40.0	45.0	50.0	55.0	60.0	70.0
Opening speed (%/s)	190	300	320	600	850	950	1050	1100	1150	1200	1250	1300	1350	1400	1450	1520
Correction advance (°)	0.0	0.0	0.0	0.0	0.0	0.0	0.0	0.0	0.0	0.0	0.0	0.0	0.0	0.0	0.0	0.0
Correction time (r)	1	1	1	1	1	1	1	1	1	1	1	1	1	1	1	1

Ignition correction for closing throttle transient

Tps (%)	20.0	25.0	30.0	32.0	35.0	38.0	43.0	50.0	54.0	57.0	60.0	65.0	70.0	75.0	80.0	85.0
Closing speed (%/s)	-820	-750	-700	-688	-664	-650	-630	-570	-540	-470	-410	-400	-400	-400	-400	-400
Correction advance (°)	0.0	0.0	0.0	0.0	0.0	0.0	0.0	0.0	0.0	0.0	0.0	0.0	0.0	0.0	0.0	0.0
Correction time (r)	1	1	1	1	1	1	1	1	1	1	1	1	1	1	1	1

The first column has the same structure on all tables:

- TPS (%): position of the throttle
- Closing / Opening speed (% / s): indicates the TPS opening speed (DTPS) in% / s, obviously being calculated as $v = (x2-x1) / t$ where:

- v = speed,
- x2 = final position
- x1 = initial position
- t = calculation time interval,

During the openings x2 will be > x1 and therefore the speed will be > 0.

During the closing of the TPS x2 will be < x1, consequently the speed will be < 0.

Obviously, a data logger is necessary to obtain the value of the DTPS. AiM offers several loggers, and for motocross the Solo2DL is the most suitable choice.

- Correction: Indicates the type of correction depending on the quantity to be modified:
 - in the case of injection, it indicates the percentage of correction of the injection
 - in the case of an advance, it indicates the offset in degrees of advance.
- Correction time (r): Indicates the number of motor revolutions for which the degree of correction is maintained.

The basic purpose of this strategy is to avoid:

1) The engine stalling during the opening of the throttle valve.

This effect is more evident at low RPM: let us assume we are in idle speed and instantly open the throttle valve, reaching values close to 100%. Instantly a very high amount of air will enter and, not having enough fuel to burn, the air pressure will rapidly increase in the intake duct, the lambda value will reach a lean peak and the engine will stall with possible shutdown.

2) Engine hesitation during gas reopening.

When the rider quickly closes the throttle valve, a quantity of fuel depending on the other tables continues to be injected. In the case of rapid closing and reopening of the throttle, during the reopening it is possible that an excess of fuel may remain, injected during the closing, creating a peak of grease and making the engine hesitant and not reactive.

Minimizing these two effects, the result will be a predictable, ready, and snappy motorcycle.

To better understand how this strategy works, let us consider the following case.

The table shown below is to be read from top to bottom and the strategy will work as shown below.

Tps (%)	2.0	3.5	4.5	9.0	15.0	20.0	25.0	30.0	35.0	37.5	40.0	45.0	50.0	60.0	70.0	80.0
Opening speed (%/s)	190	300	320	360	360	360	650	650	650	650	650	650	650	650	650	650
Correction (%)	5.0	5.0	5.0	10.0	15.0	15.0	20.0	25.0	30.0	30.0	30.0	30.0	30.0	20.0	20.0	20.0
Correction time (r)	5	5	5	5	5	5	5	5	5	5	5	5	5	5	4	4

Let us assume that the throttle is open at 10%, a value indicated in the first line between 9.0 and 15.0%.

Based on the DTPS values (Opening speed) , a linearly interpolated fuel correction value will be calculated between 10 and 15% more fuel for a period of 5 engine revolutions.

The image shown here clarifies this concept.

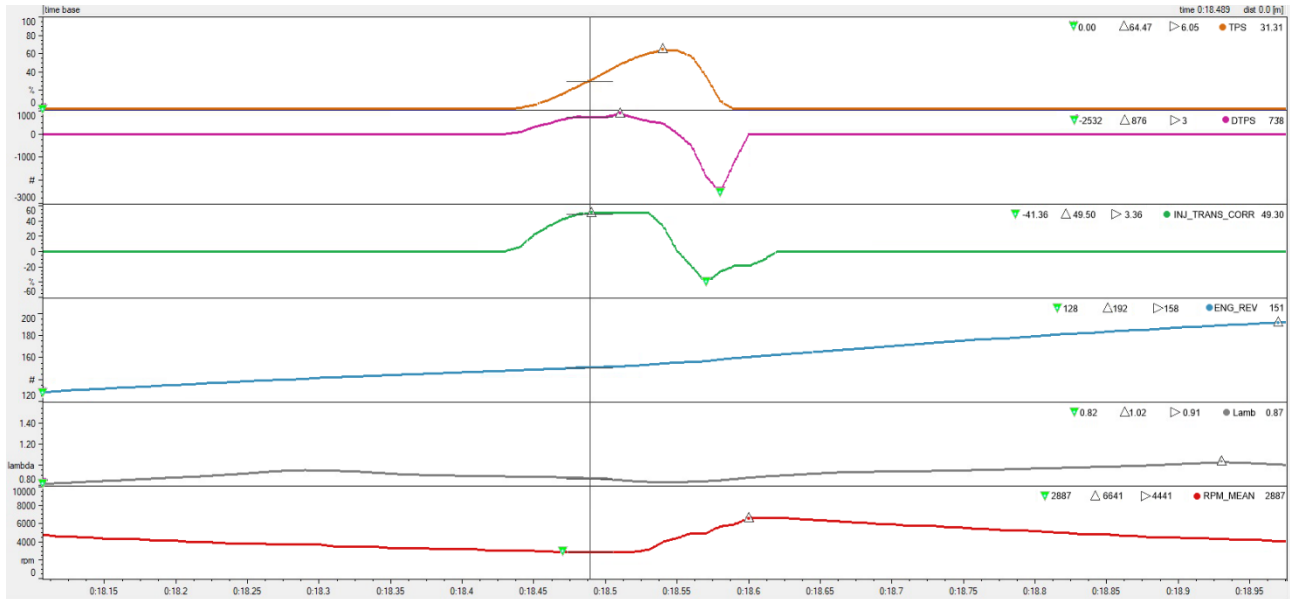

- Yellow curve: TPS
- Purple curve: DTPS (throttle opening speed)
- Green curve: INJ_TRANS_CORR (% injection correction of transients)
- Blue curve: ENG_REV (motor revolution counter)
- White curve: lambda value
- Orange curve: RPM

The three circles show:

Circle 1: throttle opening

Circle 2: Increased throttle opening speed (DTPS). Exceeding the value of the DTPS channel shown with respect to the opening speed value expressed in the table meant that the correction indicated by the same table visible in circle 3 entered.

Circle 3: Percentage correction of the injection time of transients.

The correction is recalculated 200 times per second: when, during an opening, the DTPS value is no longer higher than the value interpolated from the table, the correction remains for the number of revolutions set in the same table. The graph below shows this effect.

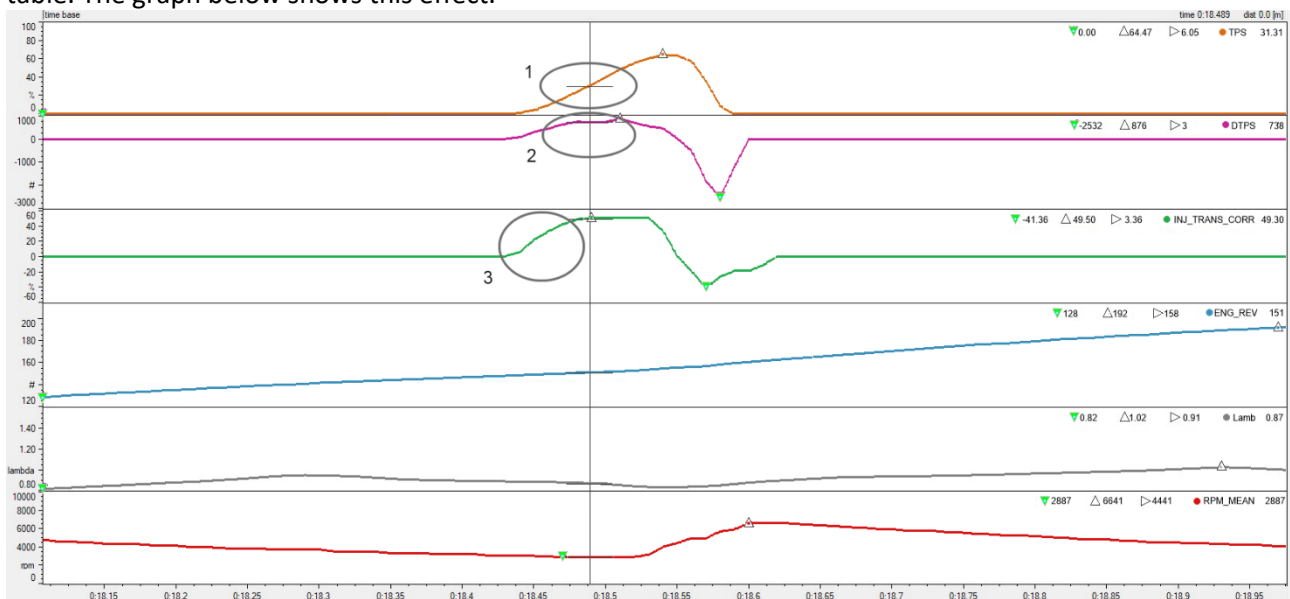

In the rectangle it can be seen how the contribution of the correction (green curve) at a certain point remains constant for the number of motor revolutions set (blue graph).
 The moment the throttle is released, the throttle lock injection transient correction table will be used.
 When the rider closes the throttle and the DTPS closing speed is less than that interpolated value from the appropriate table, the fuel percentage correction is used for a number of revolutions expressed in the table. The following image shows the throttle closure process (yellow graph) with the effects of DTPS (purple) and injection percentage correction (green).

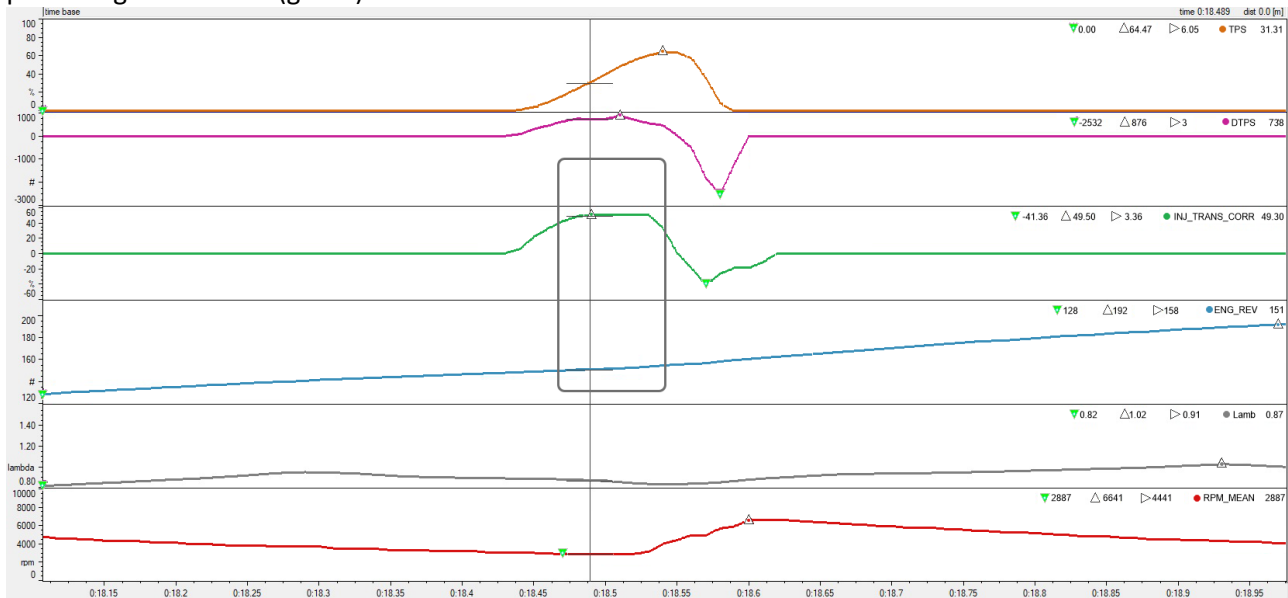

It is easy to see that during the throttle opening it is necessary to add fuel to prevent the engine from stalling, while during the closing it is essential to remove fuel.

You can check the result by observing the lambda value, highlighted in the rectangle in the image below.

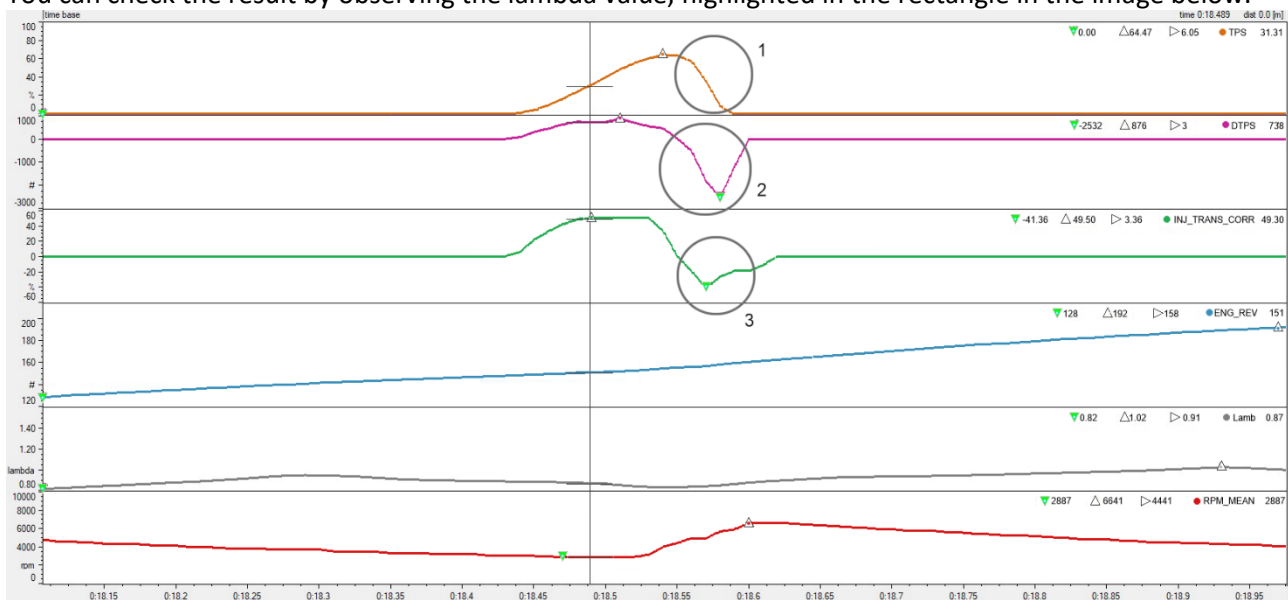

It can be noted that:

- The throttle went from 0 to 65% in 0.16 sec
- The RPM value went from 2800 to 6641 in the same period
- The lambda value, as shown in the rectangle, remained between 0.83 and 0.92 lambda with no lean-to fat peak during the transient.

Similar considerations can be made regarding the correction of the advance: during transients, increasing the advance by adding a positive offset facilitates the engine in increasing the RPM and allows an increase in the intake air thus avoiding engine stall.

In closing, however, the offset is generally absent. Only in some, very rare cases, is it appropriate to introduce a negative offset.